

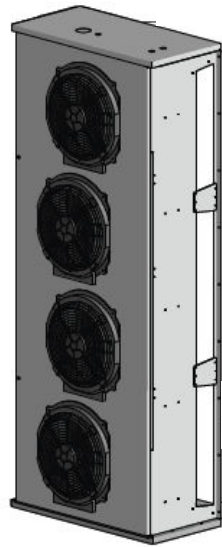

Installation, Operation and Care Manual



PBC450

PBC850

PBC1200

PBF250

PBF450

PBF850

PBF1200

Modular Blast Chiller/Freezer



This appliance is for commercial use only.

To avoid electrical shock, this appliance **MUST** be adequately grounded in accordance with local electrical codes or, in the absence of local codes, with the current edition of the national Electrical Code ANSI/ NFPA no. 70. In Canada, all electrical connections are to be made in accordance with CSA C22.1, Canadian Electrical Code Part 1 or local codes.



Warning!

This appliance is intended for use in commercial establishments where all operators are familiar with the purpose, limitations, and associated hazards of this appliance. Operating instructions and warnings must be read and understood by all operators and users.

1. This appliance must be installed on a stable, plumb and level surface.
2. **DO NOT** install this appliance in any area where it may be affected by any adverse conditions such as steam, grease, dripping water, high temperatures, etc.
3. **DO NOT** store or use any flammable liquids or allow flammable vapors near this appliance or any other appliance.
4. This appliance must be kept free and clear of any combustible materials.
5. This appliance must be kept free and clear of any obstructions blocking access for maintenance or service.



This machine is designed to be only used indoors



These appliances are heavier than they look and should be moved with proper equipment and personnel.



To reduce the risk of electric shock and injury to persons, unplug from the power supply before servicing.



This appliance must service by qualified service personnel. Failure to properly maintain and service to this appliance can and will cause injury or even death.



This appliance has parts that can cause pinching and injury, please ensure that fingers are kept away from these areas and proper attire is worn.

CHAPTER 1

Operation and Care Manual

The operation and care manual is a document issued by the manufacturing company and is an integral part of the machine. This document is adequately identified for easy tracing and/or subsequent references.

All rights relating to the reproduction and disclosure of the information contained in this handbook and the documentation quoted and/or attached are reserved. This handbook contains the information necessary for the customer and assigned personnel, to ensure the correct installation, use and maintenance of the appliance allowing it to be used safely.

Safety precautions and Manufacturer's liabilities.

Every operation related to the intended use of this appliance and its overall life cycle has been carefully and thoroughly analyzed by the manufacturing company during the design phase, construction phase and the writing of the operation and care manual. It is nevertheless understood that experience, proper training and "common sense" of the personnel operating this appliance are of the utmost importance. It is the responsibility of the operator to observe all safety precautions as outlined in this manual and to operate this appliance accordingly.

The non-observance of the safety precautions or specific warnings indicated in this manual, the use of this appliance by unauthorized personnel, violation of all safety standards regarding the design, construction, and intended use of the machine, will relieve the manufacturer from all liability in the case of damage to personnel or property.

The manufacturing company is therefore in no way responsible for the non-observance on the part of the user of the safety precautions listed in this manual.

Regulatory references

The following manual CONFORMS TO ANSI/UL Std. 471–CERT. TO CAN/CSA Std.C22.2 No. 120 – CONFORMS TO NSF 7



Disposal of this appliance after its useful life.
Electric and electronic appliances contain dangerous substances that may have potentially harmful effects

for people and the environment. It is recommended to dispose of it properly, DO NOT DISPOSE OF ELECTRICAL OR ELECTRONIC EQUIPMENT WITH OTHER MUNICIPAL WASTE.

CHAPTER 2

How to use the Operation and Care Manual

This document is an integral part of the machine. Preserve a copy of this operation manual for the entire working life of the appliance even if transferred or sold. Additional copies can be obtained from the manufacturer.

To maintain the operation and care manual in good condition:

1. Use the operation and care manual carefully, so as to not to damage its contents. In particular, do not leave the operation and care manual around after use and return it to its proper place immediately after consultation.
2. Do not remove, rip out or rewrite parts of the operation and care manual. Any changes to this manual are to be issued by the manufacturer.
3. Keep the operation and care manual in a safe place, away from environmental elements which could damage it.

CHAPTER 3

WARRANTY

PrepRite warrants to the original purchaser only that any original part that is found to be defective in material or workmanship will, at PrepRite's option, subject to provisions hereinafter stated, be replaced with a new or rebuilt part. For all other original parts, twenty four (24) months from the date of shipment of appliance. The labor warranty period is twenty four (24) months from the shipping date. PrepRite will bear normal labor charges performed during standard business hours, excluding overtime, holiday rates or any additional fees. To be valid, a warranty claim must be filed during the applicable warranty period. This warranty is not transferable.

1. All machine components normally subject to wear and are considered consumables are not included in the warranty: door gaskets, sweep gaskets,
2. Possible conditions causing electronic controls to fail include incorrect electrical supply, environmental elements, storms, lightning, water damage, could cause damages which cannot be attributed to the manufacturing company and to the manufacture of the product itself.

3. During the warranty period, for any defect in workmanship and material, all parts and labor will be covered. All warranty claims must be submitted to and conform by all statements and policies of the **OneSolutionSupport** service.
4. During the warranty period, we will pay, not to exceed, one (1) hour travel and fifty (50) miles travel. All warranty service will be performed by an authorized service center certified by the manufacturer. All parts replaced under warranty must be returned to the manufacturer for inspection before any warranty is paid.
5. Any components considered defective (door gasket, electronic control, etc.) and is determined to be caused by misuse or abuse during the warranty period will not be considered under warranty. The end user will be responsible for any repairs or parts for repairs.
6. Equipment modified in any manner from original model, substitution of parts other than factory authorized parts, removal of any parts including legs, or addition of any parts.
7. Any losses or damage resulting from malfunction, including loss of product, food product, revenue, or consequential or incidental damages of any kind.
8. Equipment damage caused by accident, shipping, improper installation or alteration.
9. Any injury caused by failure to abide by these written instructions, improper installation, improper electrical connections, alteration to equipment will be the responsibility of the owner.
10. This warranty is exclusive and is in lieu of all other warranties, express or implied, including the implied warranties of merchantability and fitness for a particular purpose. In no event shall PrepRite be liable for loss of use, loss of revenue or profit, or loss of product, or for any indirect, special, incidental, or consequential damages. No person except an officer of PrepRite is authorized to modify this warranty or to incur on behalf of PrepRite any other obligation or liability in connection with PrepRite equipment.

End User obligations

The end user must immediately inform the manufacturer of any safety system defect and/or any malfunction he or she is aware of.

It is strictly forbidden for the end user and/or any third parties (excluding duly authorized service personnel of the manufacturer) to make modifications of any kind to the appliance, its functions or to this technical publication. In case of malfunctions or defects due to the non-observance of the above, the manufacturing company cannot be held responsible for the consequences.

CHAPTER 4

GENERAL SAFETY PRECAUTIONS

1. Never touch the metal parts of the machine with wet or damp hands;
2. Unqualified or untrained personnel are not allowed to use the machine without supervision.
3. Electrical safety of the machine is ensured by a properly grounded electrical circuit.
4. The use of an extension cord is not allowed and may result in injury or death.
5. Always switch off and disconnect the appliance from the power supply before beginning any general cleaning or maintenance operation.
6. Clean appliance coating, panels and controls using soft and dry cloths, or cloths slightly soaked in mild detergent solution.

CHAPTER 5 INSTALLATION

Carefully remove the appliance from the carton or crate. **Note:** Do not discard the carton and other packaging material until you have inspected the unit for hidden damage and tested it for proper operation.



Warning!

These appliances are heavy and can be easily damaged if not removed from the skid correctly. Use the proper lifting equipment and protect the base from damage while lifting appliance from the skid. Do not drop appliance on its base or extreme damage will occur.

Location

To ensure proper operation of this appliance and its components, this appliance must be installed on a stable, plumb and level surface.



DO NOT store or use any flammable liquids or allow flammable vapors near this appliance or any other appliance.



DO NOT install this appliance in any area where it may be affected by any adverse conditions such as steam, grease, dripping water, high temperatures, etc.



Disconnect the appliance from power before performing any service or maintenance operation which may require parts. This appliance must be grounded properly.



These appliances require a dedicated circuit and cannot be shared by another appliance or damage to compressor, motors, blown fuses or tripped circuits will be cause, which will not be covered under warranty.



Because this appliance rapidly moves air in the chamber, to remove heat from the product, clearances must be maintained as specified for the evaporator(s) coil(s). This appliance must have adequate ventilation space to allow heat to be dissipated from the condenser, as well as it needs adequate ventilation to cool the condenser. **Please allow a minimum or 24" air gap from the back, sides and from the front for adequate ventilation.** In locations with excessive dust, dirt, cleaning of the condenser coil may need to be performed on a fairly regular basis. This is the customer's responsibility and must be performed by a qualified service technician or damage to the components can and will occur. Do not use caustic cleaners on the condenser coil as it may cause leaks to the sealed system.

The success or failure of the blast chiller/freezer is greatly impacted by the proper installation of this product. Because the design of the blast chiller/freezer requires it to move a large volume of air through the evaporator coil, to allow the condenser to dissipate that heat outside of the chamber, the clearance specifications must be followed. The coil(s) are designed to adequately handle the rated BTU capacity in a very controlled space. Overloading, installing the coils in too large of an area, failure to maintain clearances, etc., will all impact the performance of this system.

Installation

This manual will cover all models of the blast chiller/freezer. Please locate the diagram and installation instructions that closely matches your product. The various models will consist of either a Master Coil (TREVAASSY01) or 1 or 2 Slave Coils (TREVAASST02).

Assemble the panels, paying attention to the wall where the coil is to be installed on. There must be a minimum of ½" plywood built into the panels to adequately support the mounting of the coil. Once the mounting surface is identified, find the center of the wall and mark it.

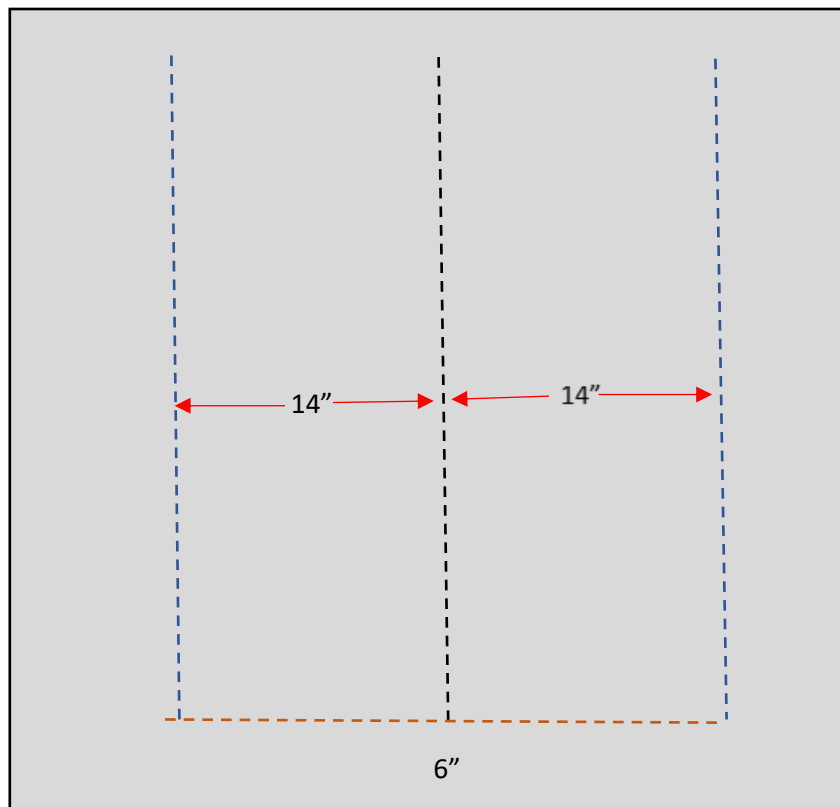

If this is a one (1) coil system, the black line will be the center of chamber. Measure a minimum of 6" off the floor and make a mark (orange line). The outside of the coil is 28", so ½ of that is 14". Measure from the center line 14" to the right or left and make a mark (blue lines), that will be the outside edge of the coil mounting. Before mounting the coil ensure that there is at least 4" minimum to 7" maximum from each side of the coil to the wall. If the desired clearances are met, then before mounting the coil, determine where the refrigeration lines exit the top of the coil, as well as the electrical connection conduits and drill those holes in the ceiling. Make the holes as small as possible, so they can be easily sealed. Plan for the installation of the drain. This is a ¾" female fitting that can be used for copper, PVC, CPVC, galvanized or a hose. Ensure that the drain has the correct pitch, to allow it to drain rapidly. There is no need to install a heat tape. If a trap is installed, it must be outside the chamber. Fasten the coil to the wall using a minimum of 6 screws on each side, in the holes provided. These screws must be stainless steel, #10, hex head or Phillip screws, 1" in length.

PBF 250, PBF450, or PBC450 Single Coil

System (TREVAASSY01)

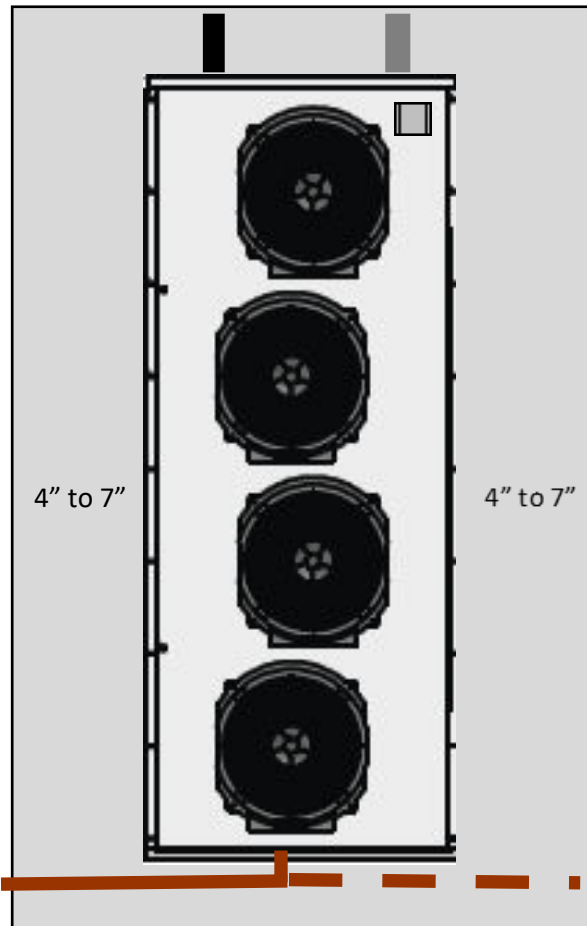

Top

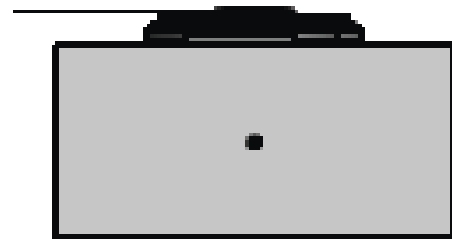

Bottom

This is the typical single coil system, such as the **PBF450** or **PBC450**. This is the master coil (**TREVAASSY01**) and contains the air temperature and coil sensor. The air temperature sensor is located in the upper right hand corner of the coil. The installation of the electrical box and front control panel will be covered later in this manual.

PBF850 or PBC850 Double Coil System (1 – TREVAASSY01 and 1 – TREVAASSY02)

Assemble the panels, paying attention to the wall where the coils are to be installed on. There must be a minimum of $\frac{1}{2}$ " plywood built into the panels to adequately support the mounting of the coils. Once the mounting surface is identified, find the center of the wall and mark it.

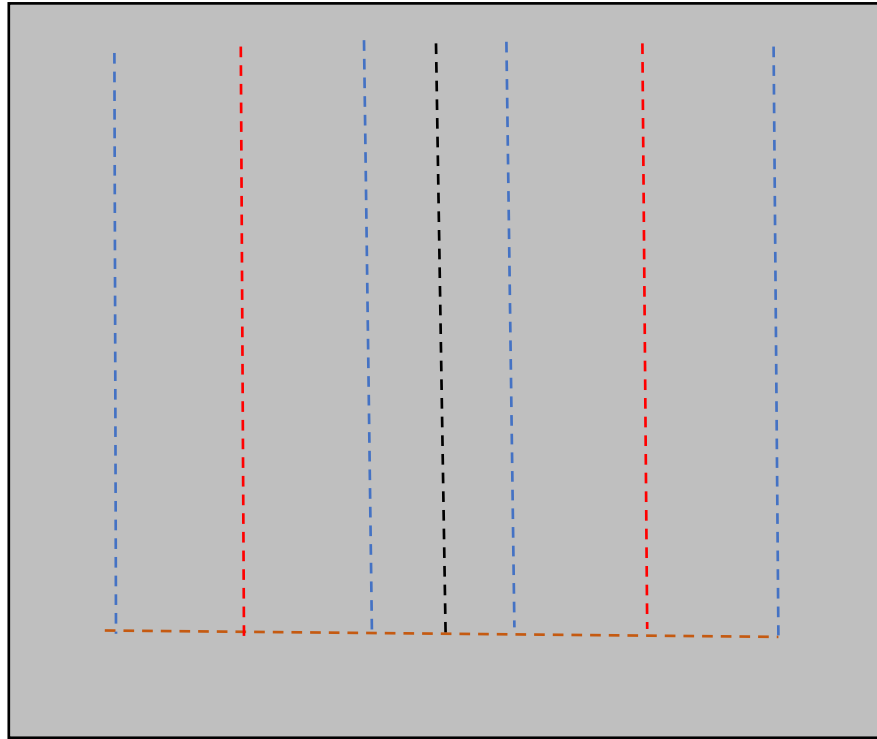

If this is a two (2) coil system, the black line will be the center of the chamber. Measure a minimum of 6" off the floor and make a mark (orange line). Next measure the distance between the center line of the chamber and either inside wall and make a mark (red lines). This will be the center of each coil. The outside of the coil is 28", so $\frac{1}{2}$ of that is 14". Measure from the center line 14" to the right or left and make a mark (blue lines), that will be the outside edge of the coil mounting. Before mounting the coils ensure that there is at least 4" minimum to 7" maximum from each side of the coil to the wall or to the adjacent coil. If the desired clearances are met, then before mounting the coil, determine where the refrigeration lines exit the top of the coil, as well as the electrical connection conduits and drill those holes in the ceiling. Make the holes as small as possible, so they can be easily sealed. Plan for the installation of the drain. This is a $\frac{3}{4}$ " female fitting that can be used for copper, PVC, CPVC, galvanized or a hose. Ensure that the drain has the correct pitch, to allow it to drain rapidly. There is no need to install a heat tape. If a trap is installed, it must be outside the chamber. Fasten the coils to the wall using a minimum of 6 screws on each side, in the holes provided. These screws must be stainless steel, #10, hex head or Phillip screws, 1" in length.

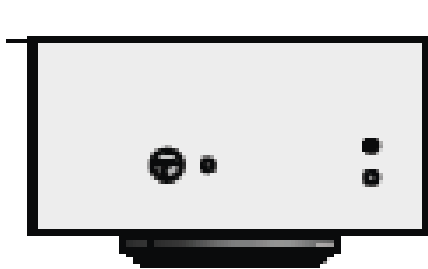
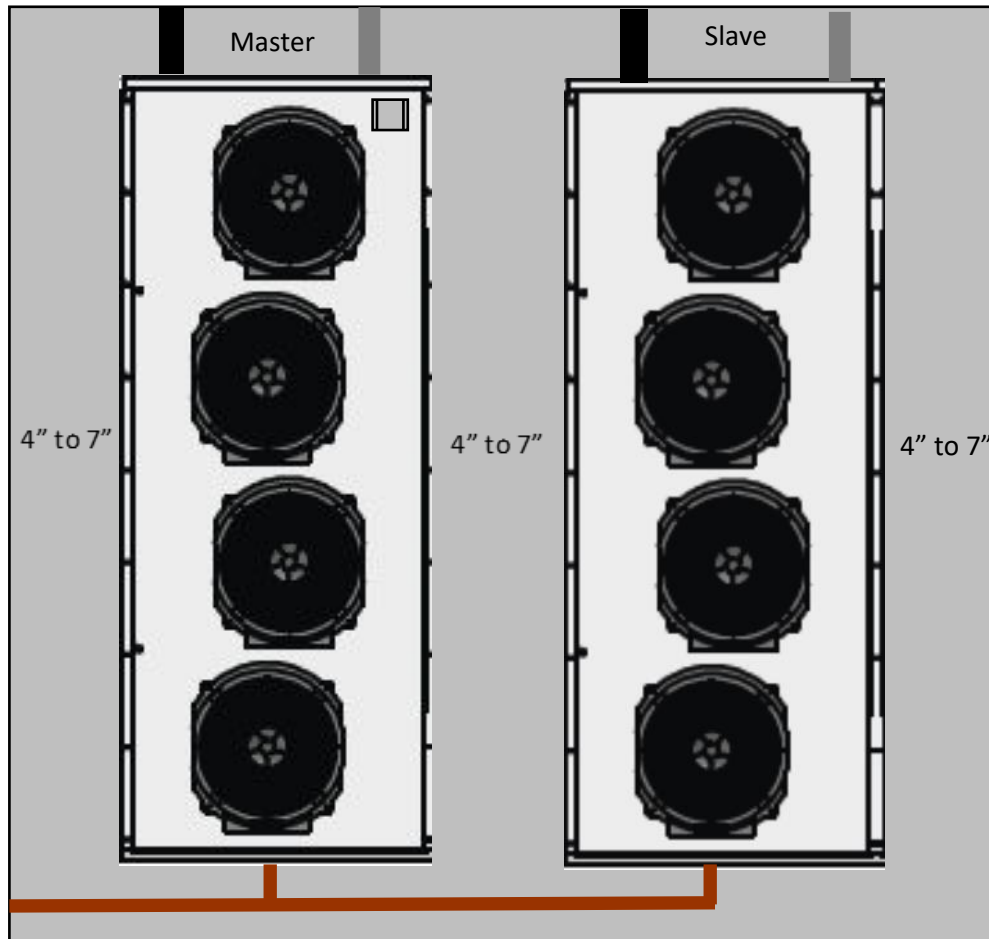

Top



Bottom

This is the typical double coil system, such as the **PBF850** or **PBC850**. This setup contains a master (**TREVAASSY01**) and slave coil (**TREVAASSY02**). The master coil contains the air temperature and coil sensors. The air temperature sensor is located in the upper right hand corner of the coil. This coil is always mounted closest to the outer door. The installation of the electrical box and front control panel will be covered later in this manual.

PBF1200 or PBC1200 Triple Coil System (1 – TREVAASSY01 and 2 – TREVAASSY02)

Assemble the panels, paying attention to the wall where the coils are to be installed on. There must be a minimum of ½" plywood built into the panels to adequately support the mounting of the coils. Once the mounting surface is identified, find the center of the wall and mark it.

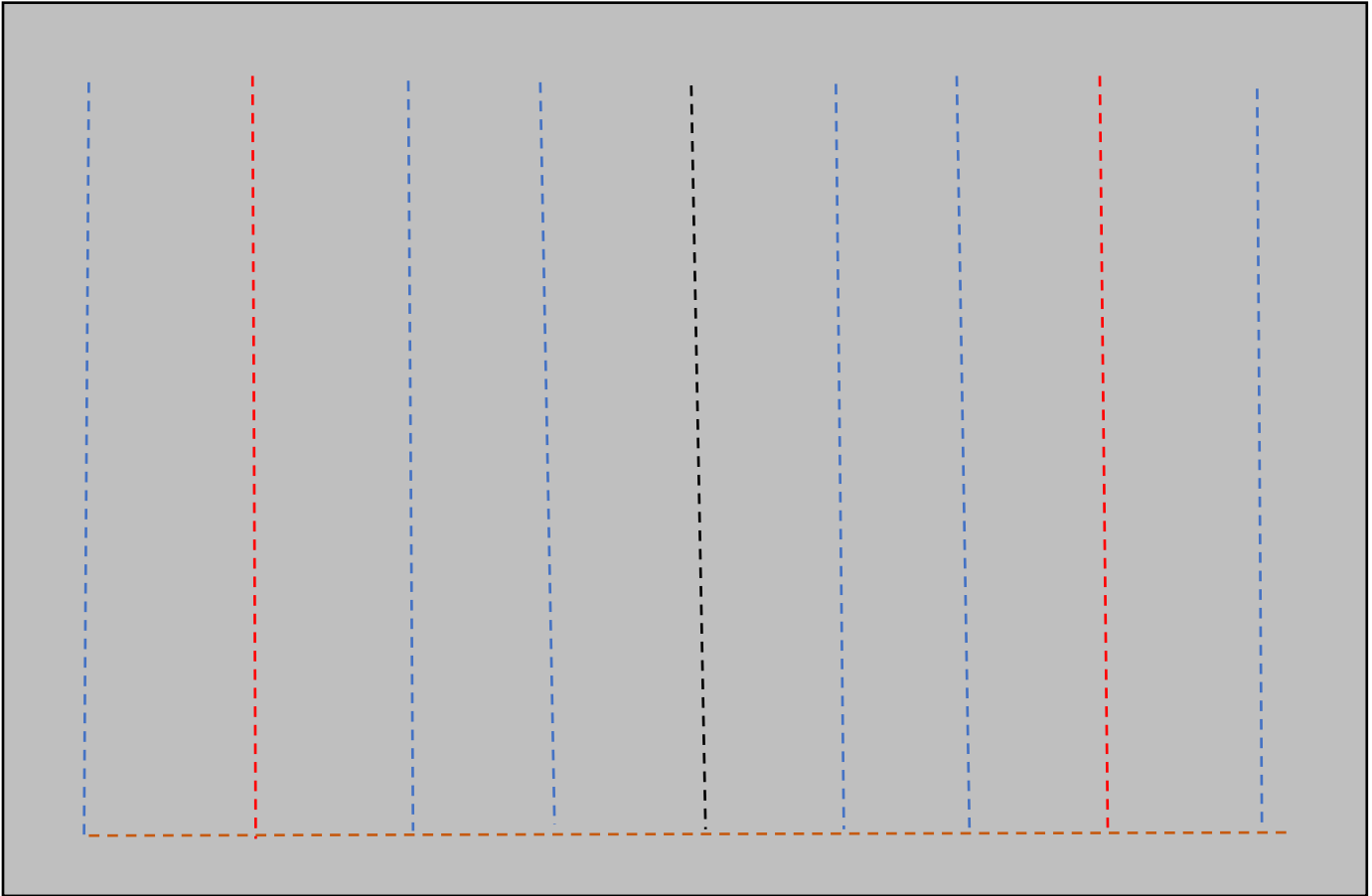

If this is a three (3) coil system, the black line will be the center of the chamber. Measure a minimum of 6" off the floor and make a mark (**orange line**). Next measure the distance between the center line of the chamber and either inside wall and make a mark (**red line**). This will be the center of each coil. The outside of the coil is 28", so ½ of that is 14". Measure from the center line 14" to the right or left and make a mark (**blue line**), that will be the outside edge of the coil mounting. Before mounting the coils ensure that there is at least 4" minimum to 7" maximum from each side of the coil to the wall or to the adjacent coil. If the desired clearances are met, then before mounting the coil, determine where the refrigeration lines exit the top of the coil, as well as the electrical connection conduits and drill those holes in the ceiling. Make the holes as small as possible, so they can be easily sealed. Plan for the installation of the drain. This is a ¾" female fitting that can be used for copper, PVC, CPVC, galvanized or a hose. Ensure that the drain has the correct pitch, to allow it to drain rapidly. There is no need to install a heat tape. If a trap is installed, it must be outside the chamber. Fasten the coils to the wall using a minimum of 6 screws on each side, in the holes provided. These screws must be stainless steel, #10, hex head or Phillip screws, 1" in length.

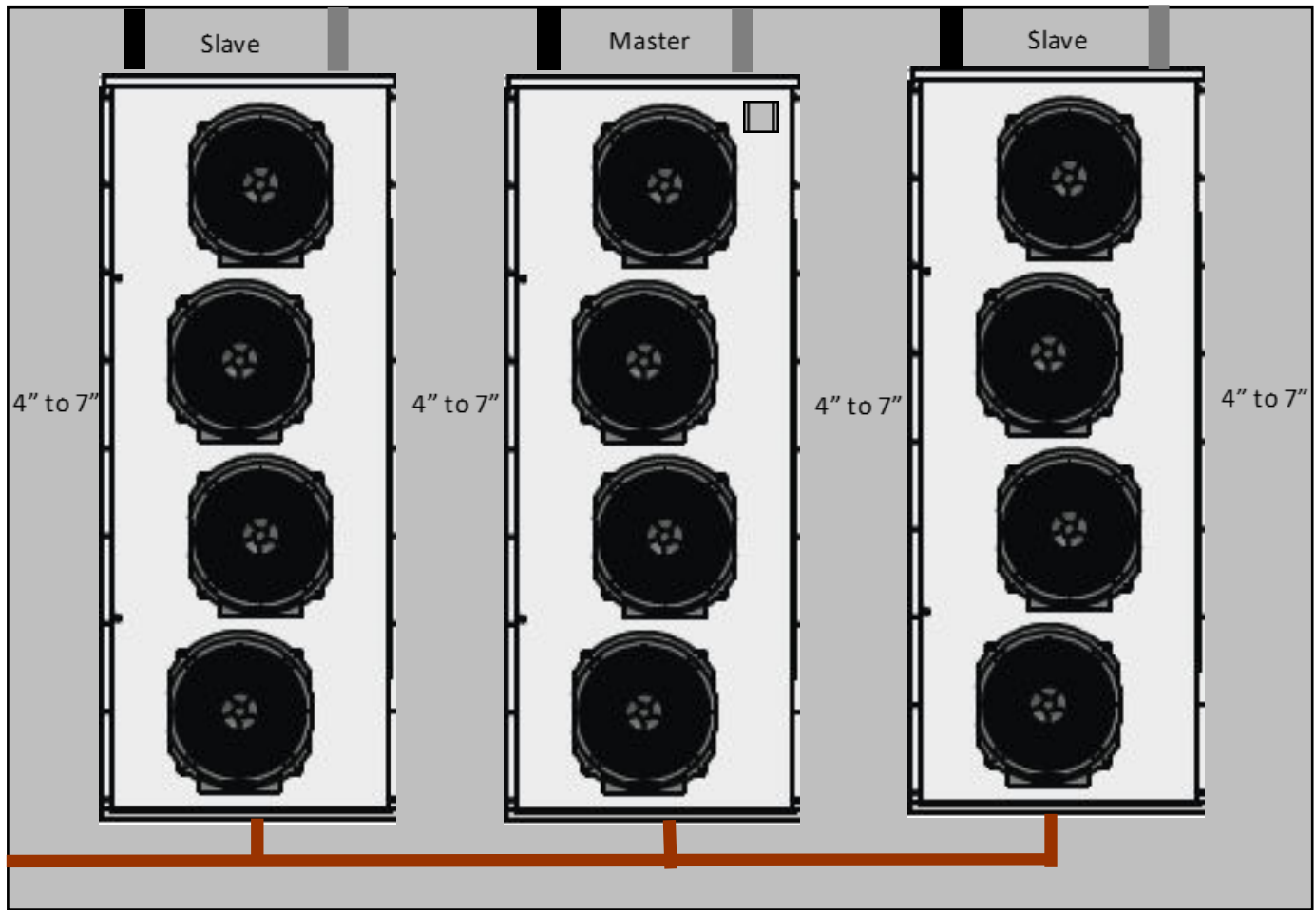

Top



Bottom

This is the typical triple coil system, such as the **PBF1200** or **PBC1200**. This setup contains a master (**TREVAASSY01**) and 2 slave coils **TREVAASSY02**). The master coil contains the air temperature and coil sensors. The air temperature sensor is located in the upper right hand corner of the coil. This coil is always mounted in the middle of the cabinet, between the 2 slave coils. The installation of the electrical box and front control panel will be covered later in this manual.

Refrigeration Piping

When piping any refrigeration systems in, the rules still apply. Any vertical rise of more than 20 feet, requires an oil trap installed in the suction line. Any refrigeration piping run of more than 50 feet requires increasing the piping diameter by 1 size, i.e.: 1 1/8" suction to 1 1/4" suction, 3/8" liquid to 1/2" liquid. Coils can be manifolded together above the box, per the below example. **NOTE:** The solenoid valve must be provided in the field and must be located within 6 feet of the electrical box, so the provided electrical can be used.

The same set up can be used for a 2 coil system.

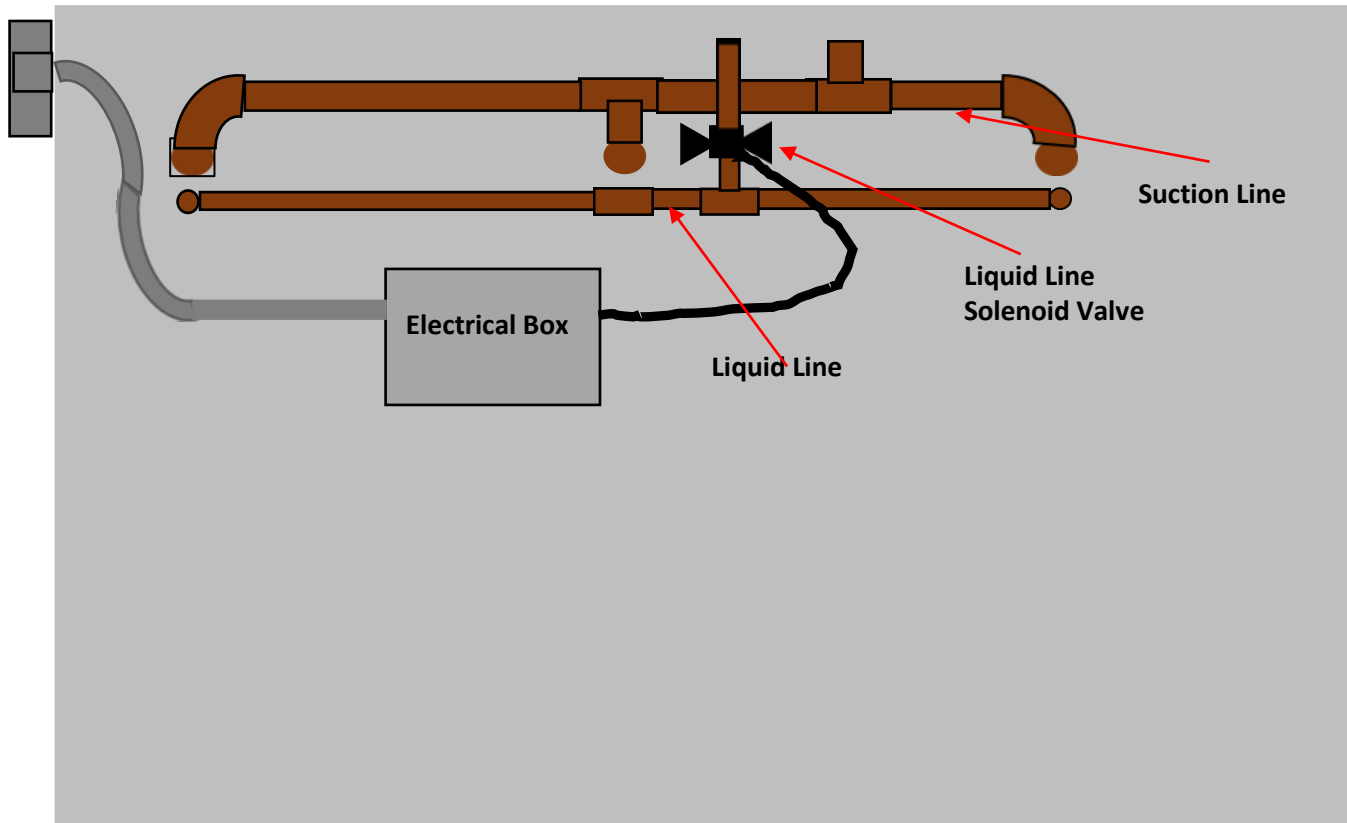

Make sure that long sweep 90 degree elbows are used and use Tee's for the connection points. After assembly and pressure checking the system with dry nitrogen, ensure that all suction lines and wrapped and sealed with foam insulation

Control Panel Mounting

The control must be mounted in an ambient controlled environment. It cannot be mounted in an excessively hot, cold or a high humidity area. The control panel mounts to the front of the Blast Chiller compartment and should be mounted a minimum of 60" to the center of the screen or a maximum of 70" to the center of the screen. ½" plywood backing must be provided in the panel for the control panel to be mounted to. To access the mounting bracket, remove the 4 screws from the bezel and carefully remove the control. The display is connected by a wire connector and can be removed for installation. It only connects one way, so ensure it is reconnected before re-installing the display. The control box assembly can be attached to the front of the Blast Chiller cabinet by means of 4 #10 stainless steel ¾" screws. Please ensure the control panel is level and plumb. Next install the conduit cover backing plate behind the non-metallic conduit and fasten it with #10 stainless steel screws. The cover and backing plate can be trimmed if they are too long. Slide the stainless steel cover over the backing plate and seal to the control top with silver or clear silicone.

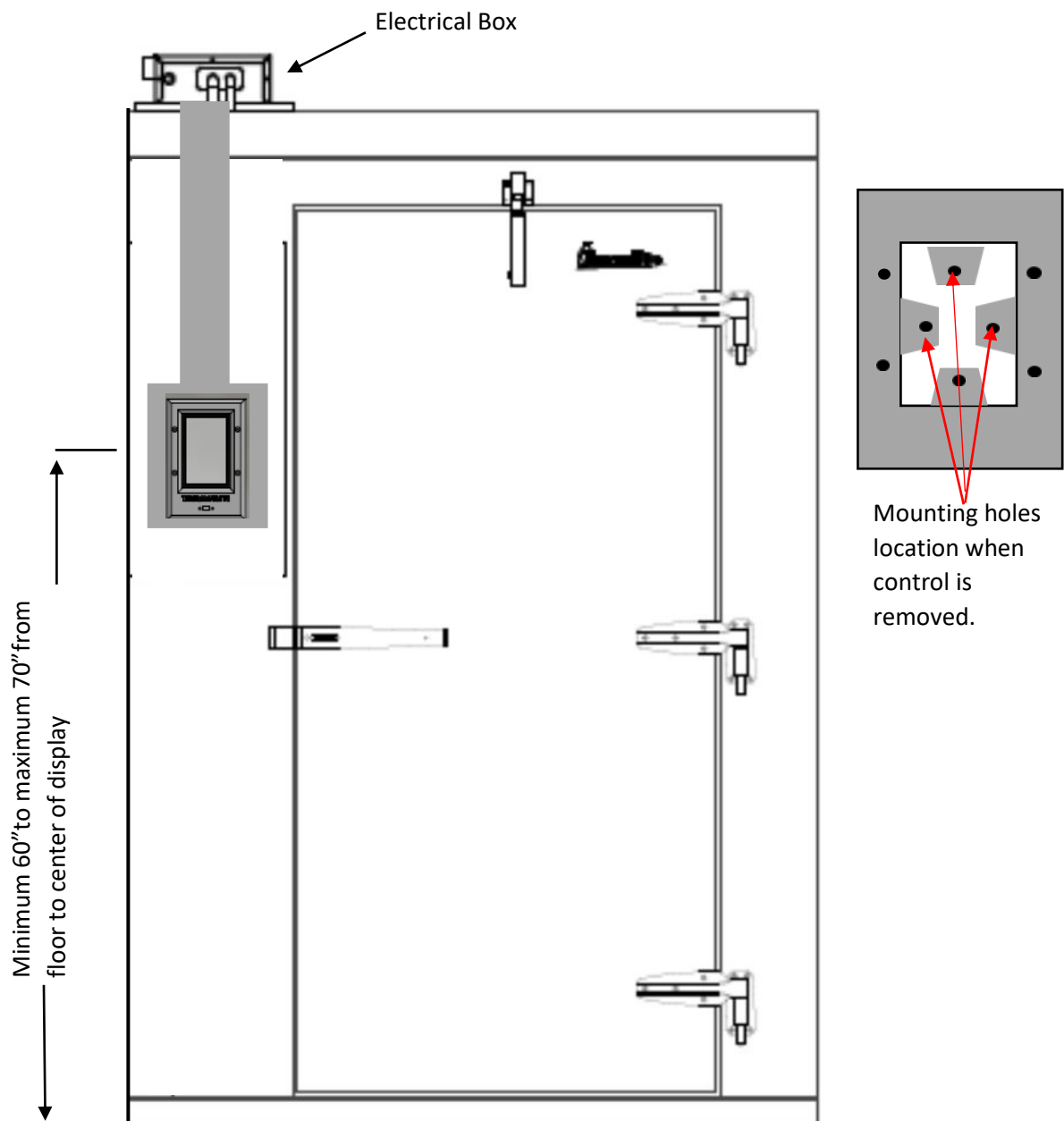

Electrical Box

The electrical box is to be mounted on the outside ceiling of the box and is where the electrical connections are made. This box must be accessible for service and cannot be in an area affected by high or low temperatures or excessive humidity. The electrical connections are prewired for 1, 2 or 3 coils and use polarized plug connections. The electrical panel is also prewired for the door switch and the door heater and those connections are marked. Please see pictures for the correct connections to use.

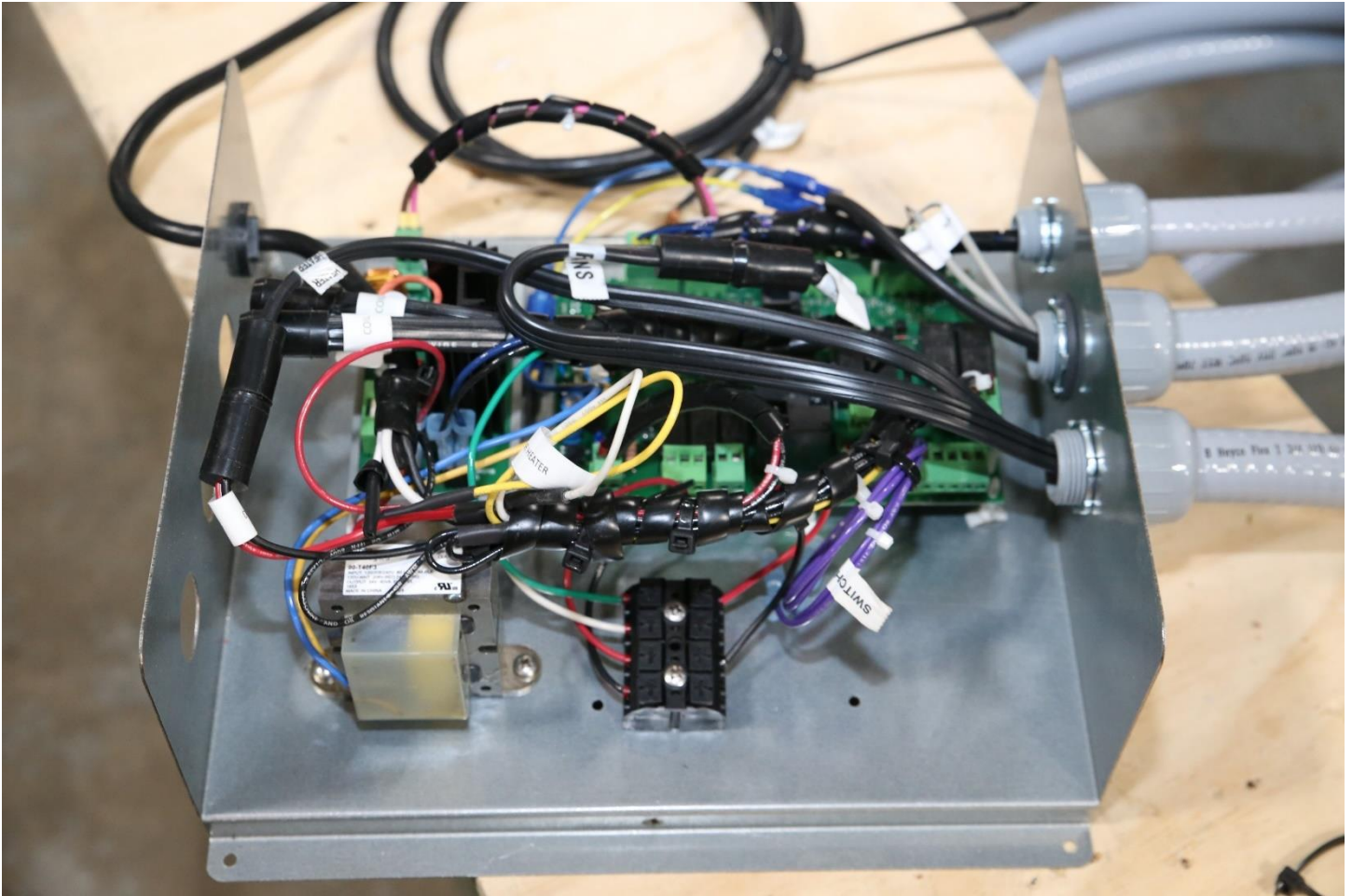

To access the wiring, remove 2 screws and remove the cover. Insert the non-metallic conduit into the box as shown and connect the various connectors as described below. If there are 2 coils or 2 coils, use the open holes to make the connections. Make sure you replace the cover when finished. The electrical connections on the terminal strip are Black – 120VAC, Red – 120VAC, White – Neutral, Green – Ground. This requires a **208/240VAC, 1PH 30Amp** circuit with a **Neutral** and a **Ground**.

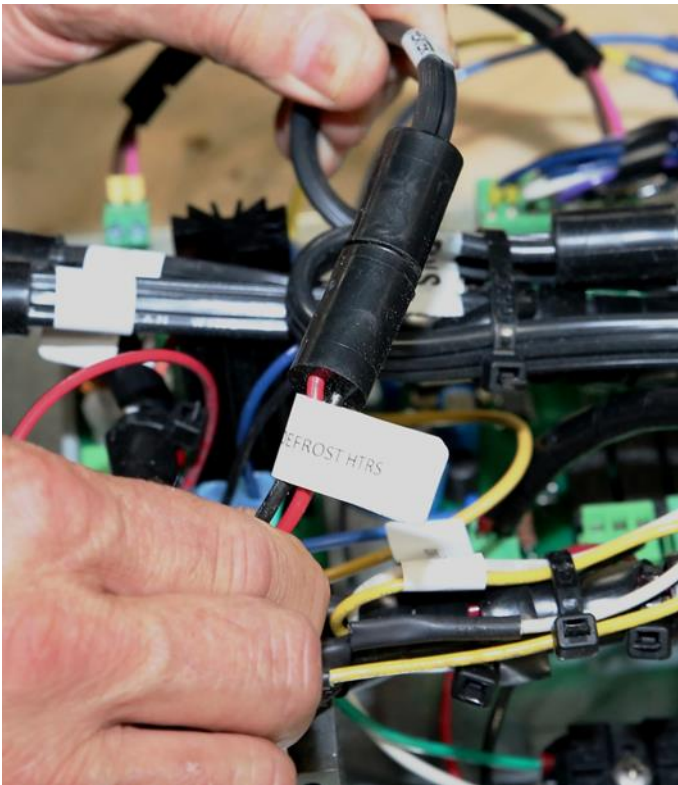

Defrost Heater Connector (2 pole)

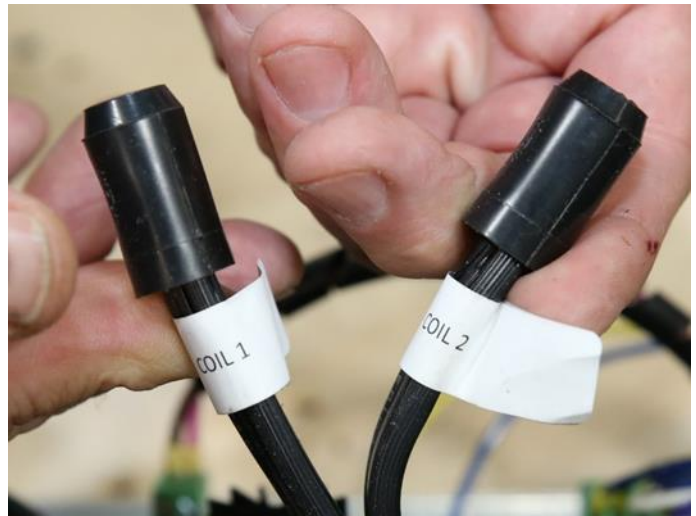

Fan Motor Connections for Master or Slave Connections. If there is 1 coil, then use coil 1, 2 coils use 1 and 2, 3 coil, use 1, 2 and three (3 pole connector)



Door Switch wires are purple and are labeled, if There are 2 door switches, wire door switches in series.

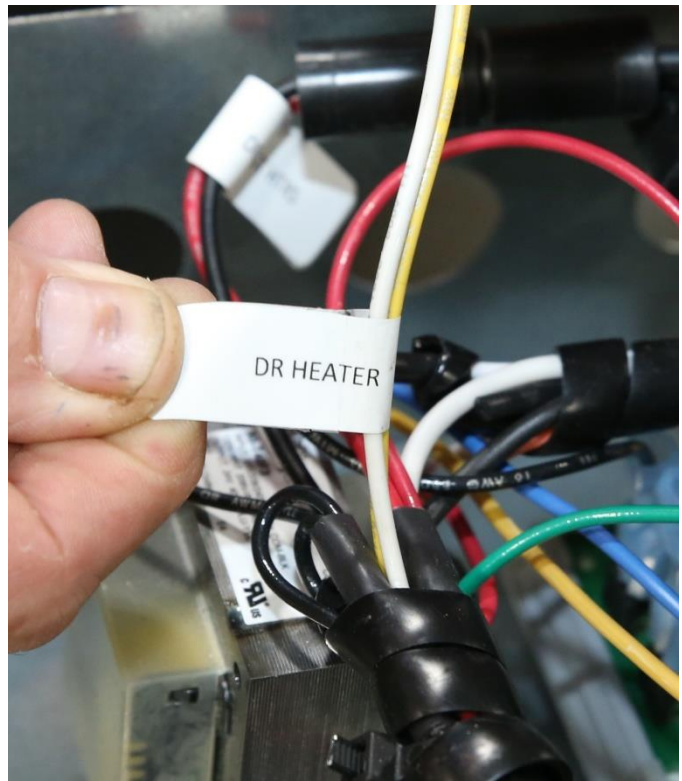

The door heater (120VAC) wires are yellow and white and are labeled.

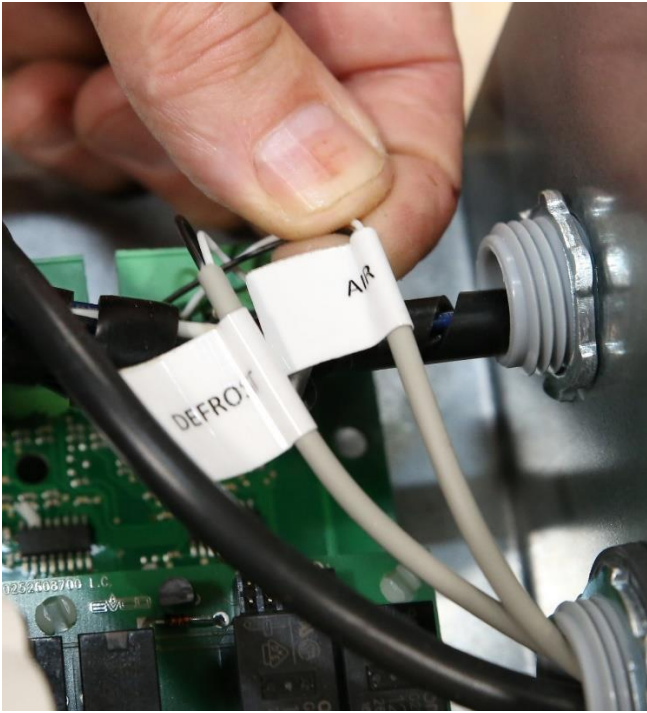

The Air Temperature Sensor and Coil Sensor.



The Solenoid Cable is wrapped up and labeled. This is for a 208/240VAC Solenoid Valve Coil.

Drawn By: K. Kreuzscher
Date Drawn: January 12, 2018
Revision No. TQCFM - Mod 5
Model No. Covered:
TREVAASSY01
TREVAASSY02
TQCFM 450
TQCFM 850
TQCFM 850
TQCFM1200
TQCFM1200
208 - 240VAC, 60hz, 1 PH
TQCFM 450 - 30A (20.2A actual)
TQCFM 450 - 30A (20.2A actual)
TQCFM 850 - 30A (23.4A actual)
TQCFM 850 - 30A (23.4A actual)
TQCFM 1200 - 30A (26.6A actual)
TQCFM 1200 - 30A (26.6A actual)

TQCFM 450 - 1 Master Coil
 TQCFM 450 - 1 master coil, change orifice
 TQCFM 850 - 1 Master Coil, 1 Slave Coil
 TQCFM 850 - 1 Master Coil, 1 Slave Coil, change orifice
 TQCFM 1200 - 1 Master Coil, 2 slave Coils, Master goes in Center
 TQCFM 1200 - 1 Master Coil, 1 Slave Coil, change orifice, Master goes in Center.

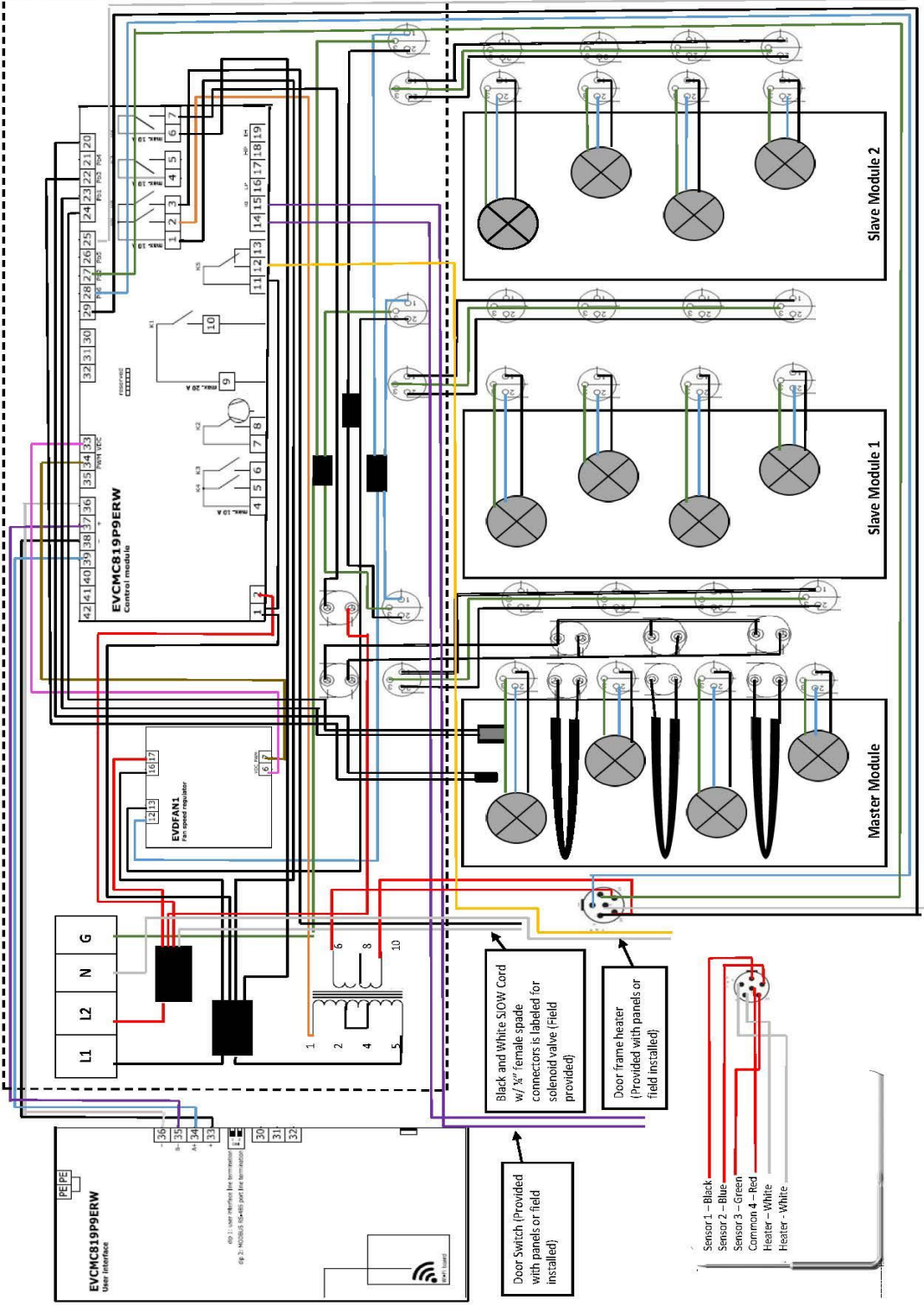

Black and White SCOW Cord
 w/ 3/8" female spade
 connectors is labeled for
 solenoid valve (Field
 provided)

Door frame heater
 (Provided with panels or
 field installed)

Sensor 1 - Black
 Sensor 2 - Blue
 Sensor 3 - Green
 Common 4 - Red
 Heater - White
 Heater - White

Door Switch (Provided
 with panels or field
 installed)

Master Configuration

TREVAASSY01

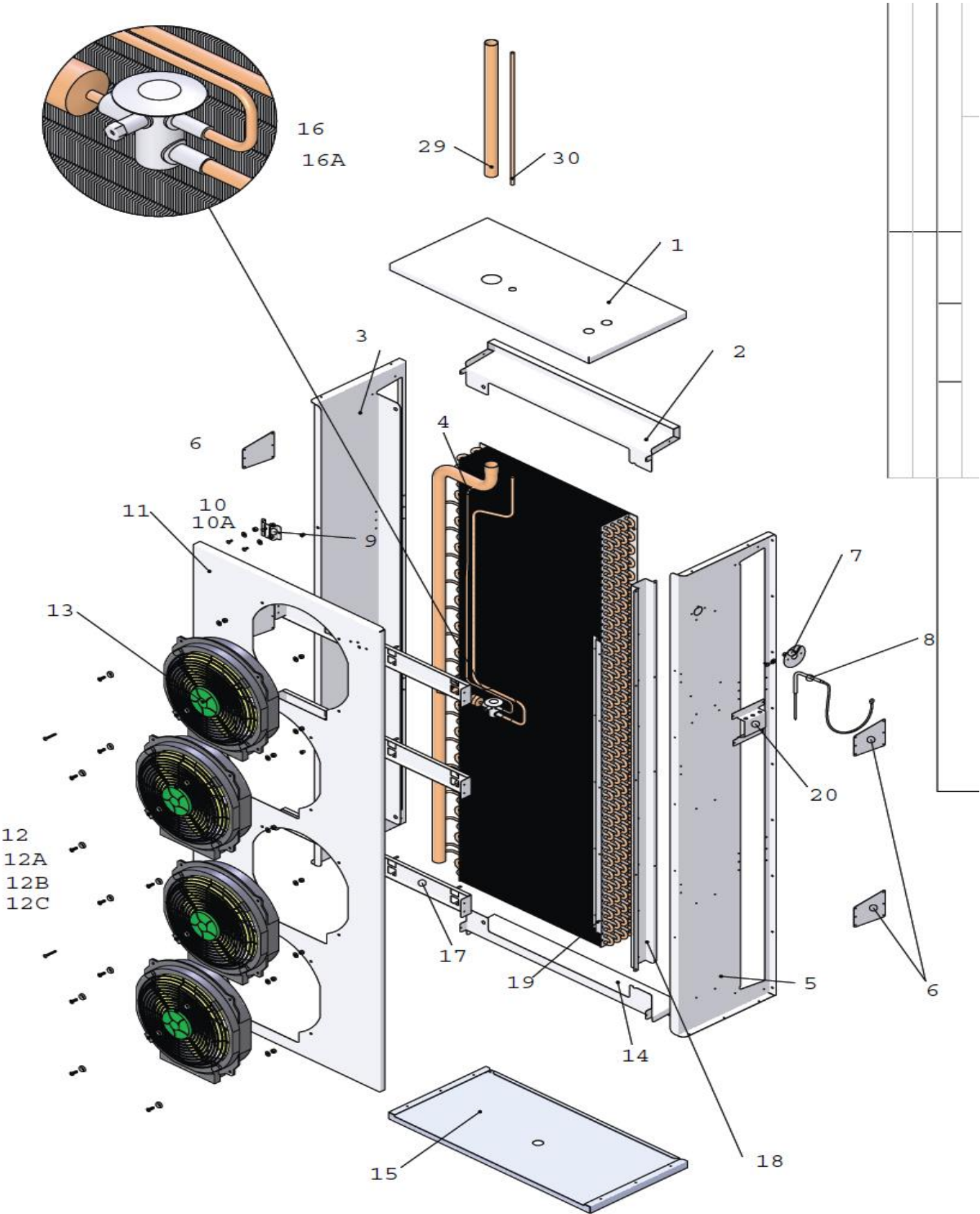

Wiring Box Assembly
("Master" configuration only)

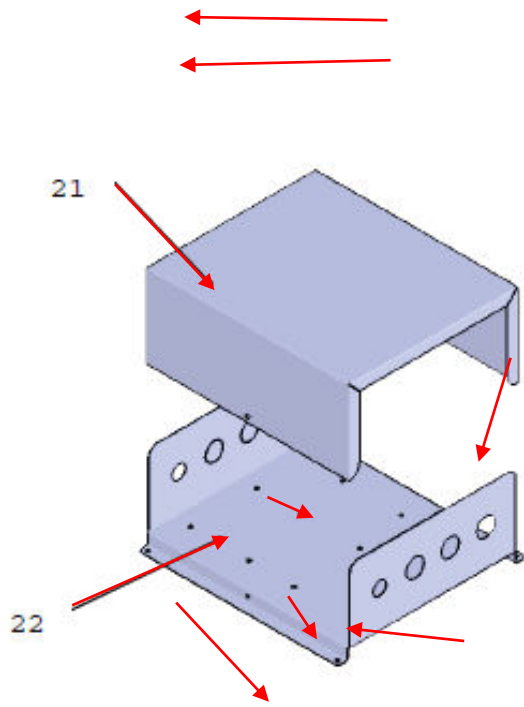

Control Panel Ass
("Master" configurati

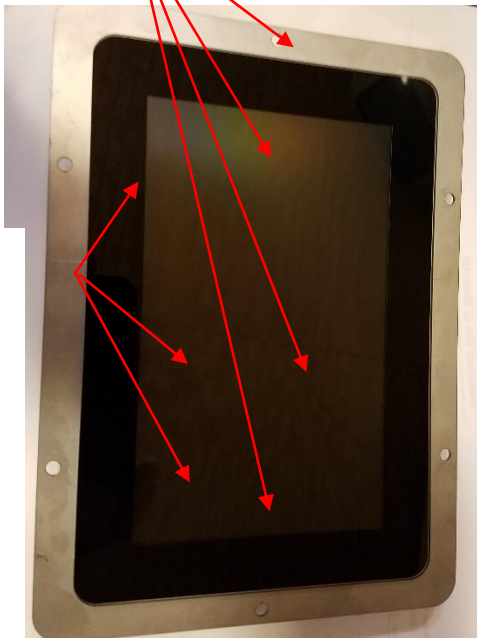
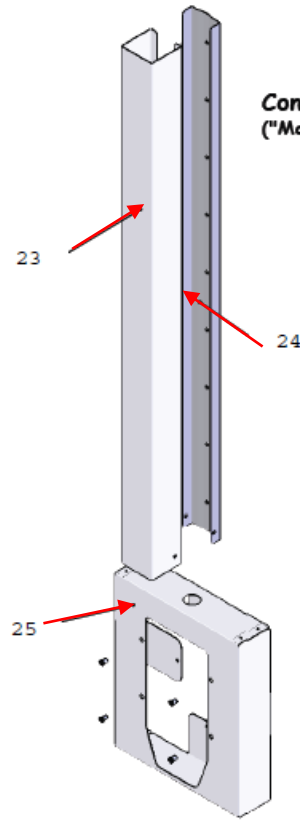

26 - Touch Screen Display

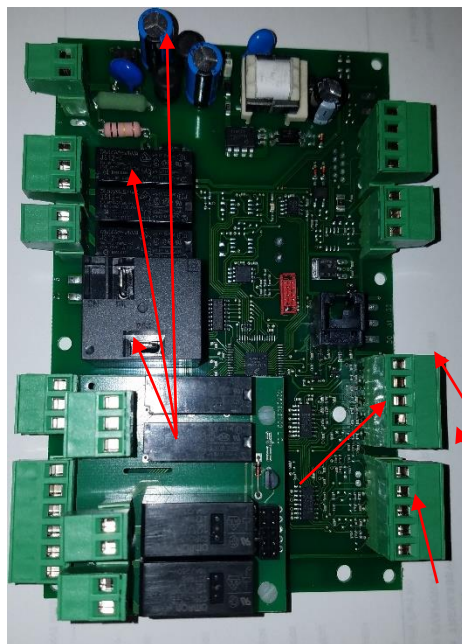

27 - Relay Board

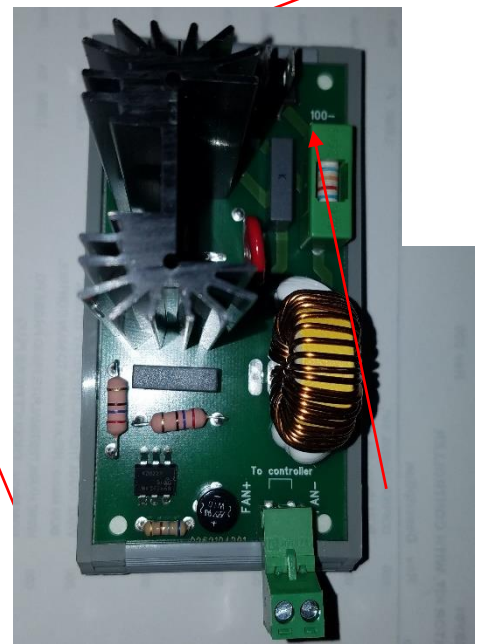

28 - Fan Control Board

Slave Configuration

TREVAASSY02

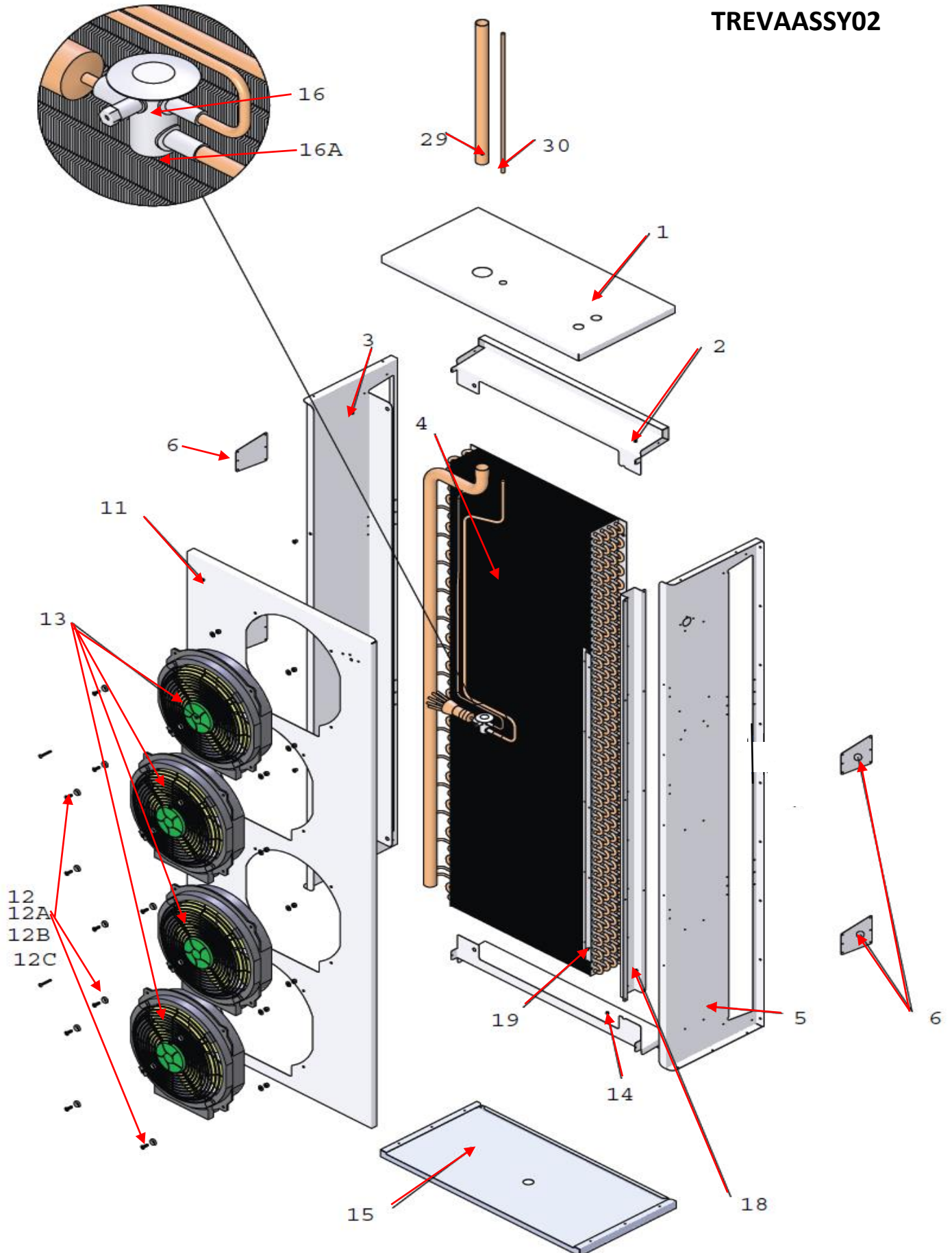

Master and Slave Coil Parts List

Number	Part Description	Quantity	Reference No.	Everidge Part No.
1	Coil Cabinet Top Panel	1	MLR04	
2	Coil Cabinet Upper Deflector	1	MLR06	
NS	1/8" Stainless Steel Rivets	48		
3	Left Side Panel Coil Cabinet	1	MLR02	
4	Evaporator, Grey Epoxy, 64" x 20" Prepped	1	RWE605	
NS	Reducer Coupling 7/8" to 1/2"	1	RWFR.8.5	
5	Right Side Panel Coil Cabinet	1	MLR01	
6	Coil Cabinet Side Supports	4	MLR08	
7	Product Probe Connector Plate	1	MLR12M	
8	Single Point Product Probe	1	EVTPNB38F200	AX4725
NS	Single Point Heated Product Probe (Opt)	1		
NS	Multi-Point Product Probe (Opt)	1		
NS	Multi-Point Heated Product Probe (Opt)	1	EVTPNB38S200	AX4726
NS	Multi-Single Point Product Probes (Opt)	1		
9	Air Sensor Cover	1	MLR13M	
NS	EVCO Temperature Sensor (Not Shown)	2	EVTPNW30F200	AX4724
10	10-24x1/2" Stainless Steel Truss Head Screws	4		
11	Fan Panel	1	MLR07	
11A	Stainless Steel Fan Panel Screw 10-24x1 1/2"	2		
12	3/16"x1" Stainless Steel Phillips Head Screw	16		
12A	Stainless Steel Lock washer	16		
12B	Stainless Steel Nuts	16		
13	Evaporator Fan 230VAC DC Motor	4	RWEM63	
NS	#10 Finishing Washers	16	CWZH01S	
NS	1/4-20x3/4" SS Machine Screw	16	CMBH.75SS	
NS	1/4-20 Nylock Nuts	16	CNLL01S	
14	Rear Coil Support Deflector	1	MLR05	
15	Evaporator Condensate Pan w/ 3/4" Drain	1	MLR03	
NS	SS 3/4" Half Coupling	1	RWFSHC.75	
16	TXV Valve Danfoss 068U2287	1	RWEV66	
16A	Danfoss Orifice #9 068U1039	1	RWEV94-ORF	
NS	Copper TXV Strap	1	RWEVSTRAP	
17	Thawing Heater w/Mounting Brackets	3	RWDH09	
18	Wiring Harness Channel	1	MLR09	
19	Stainless Steel Piano Hinge 1.5"x44.5"	1	HXHE51	
20	Product Probe Holder	1	MRL11M	
21	Electrical Box Cover	1	MLR18M	
22	Electrical Box Base	1	MLR17M	
22A	10-24x1/2" Stainless Steel Truss Head Screw	2		
23	Stainless Steel 36" Conduit Cover	1	MLR15M	
24	Conduit Back Plate	1	MLR16M	
25	Display Control Box	1	MLR14M	
26	EVCO Touch Screen Display Board	1	VC819DSP	AX4722
27	EVCO Touch Screen Relay Board	1	VC819RLY	AX4722

NS	Nylon Board Standoffs Richio	6	HPSTOF01	
28	EVCO Fan Speed Module	1	EVDFAN1	AX4723
29	Copper Tubing 1 3/8"	1	THERMTUBE01	
30	Copper Tubing 3/8"	1	THERMTUBE03	
NS	Control Bezel (Not Shown)	1		
NS	8-32x 1 1/4" Black Phillip Head Screws	4	CMPF1.25S	
NS	#8 Black Flat Washers	4		
NS	Insert Rivet Nut 8-32	4	CRN02	
NS	EVCO Cable USB 2.0 .5M JST 1256800336	1	1256800336	AX4849
NS	6-32x1/2" Phillips Pan SS	2	CACD.50S	
NS	USB –A Tethered Dust Cover(Not Shown)	1	ZZ-DC-USB-AW	
NS	Main Control Wire Harness	1	THERMWIRE01	
NS	Fan Wire Harness	1	THERMWIRE02	
NS	Heater Wire Harness	1	THERMWIRE03	
NS	Probe Sensor Wire Harness	1	THERMWIRE04	
NS	Wire Harness, Fan/Control Coil to Electrical	1	THERMWIRE05	
NS	Wire Harness Relay to Display Board	1	THERMWIRE06	
NS	Product Probe Wire Harness Single Point	1	THERMWIRE13	



ICS THERMALRITE CROWNTONKA LOTEMP DOORS

15600 37th Ave N • Suite 100 • Plymouth, Minnesota 55446
888-227-1629 • www.Everidge.com