

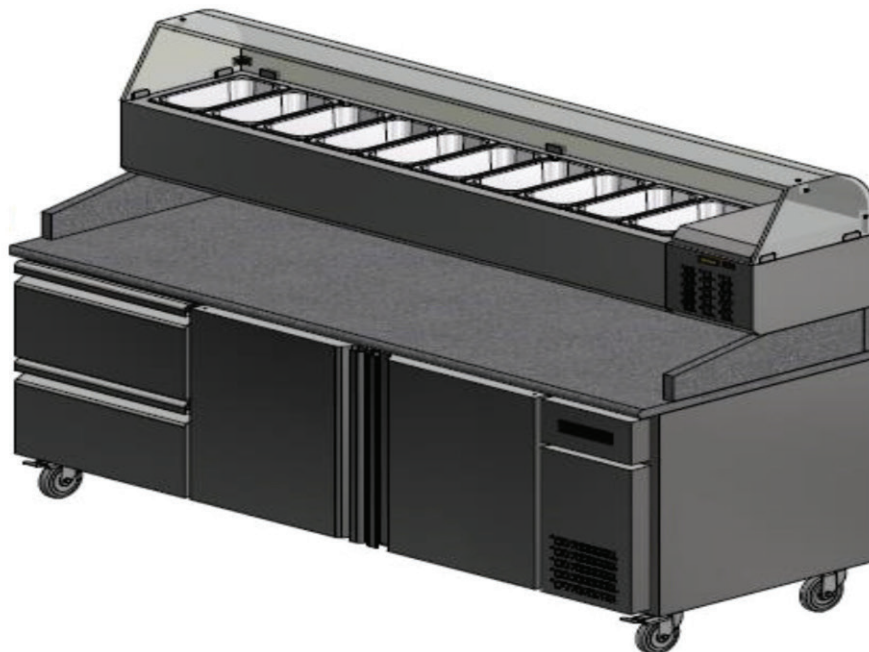

**Operation and Care Manual  
For**

**PPT481C  
PPT602C  
PPT843C  
PAD7**

**Series Refrigerated Prep Tables**







This appliance is for commercial use only.

To avoid electrical shock, this appliance **MUST** be adequately grounded in accordance with local electrical codes or, in the absence of local codes, with the current edition of the national Electrical Code ANSI/NFPA no. 70. In Canada, all electrical connections are to be made in accordance with CSA C22.1, Canadian Electrical Code Part 1 or local codes.



### **Warning!**

This appliance is intended for use in commercial establishments where all operators are familiar with the purpose, limitations, and associated hazards of this appliance. Operating instructions and warnings must be read and understood by all operators

1. This appliance must be installed on a stable and level surface.
2. **DO NOT** install this appliance in any area where it may be affected by any adverse conditions such as steam, grease, dripping water, high temperatures, etc.
3. **DO NOT** store or use any flammable liquids or allow flammable vapors in the vicinity of this appliance or any other appliance.
4. This appliance must be kept free and clear of any combustible materials.
5. This appliance must be kept free and clear of any obstructions blocking access for maintenance or service.



This machine is designed to be only used indoors.



These appliances are heavier than they look and should be moved with proper equipment and personnel.



To reduce the risk of electric shock and injury to persons, unplug from the power supply before servicing.



This appliance must service by qualified service personnel. Failure to properly maintain and service this appliance can and will cause injury or even death.



This appliance has parts that can cause pinching and injury. Please ensure that fingers are kept away from these areas and proper attire is worn.

## CHAPTER 1 Operation and Care Manual

The operation and care manual is a document issued by the manufacturing company and is an integral part of the machine. This document is adequately identified for easy tracing and/or subsequent references.

All rights relating to the reproduction and disclosure of the information contained in this handbook and the documentation quoted and/or attached are reserved. This handbook contains the information necessary for the customer and assigned personnel, to ensure the correct installation, use and maintenance of the appliance allowing it to be used safely.

### Safety precautions and Manufacturer's liabilities

Every operation related to the intended use of this appliance and its overall life cycle has been carefully and thoroughly analyzed by the manufacturing company during the design phase, construction phase and the writing of the operation and care manual. It is nevertheless understood that experience, proper training and "common sense" of the personnel operating this appliance are of the utmost importance. It is the responsibility of the operator to observe all safety precautions as outlined in this manual and to operate this appliance accordingly.

The non-observance of the safety precautions or specific warnings indicated in this manual, the use of this appliance by unauthorized personnel, violation of all safety standards regarding the design, construction, and intended use of the machine, will relieve the manufacturer from all liability in the case of damage to personnel or property.

The manufacturing company is therefore in no way responsible for the non-observance on the part of the user of the safety precautions listed in the manual.

### Regulatory references

The following manual CONFORMS TO ANSI/UL Std. 471-CERT. TO CAN/CSA Std.C22.2 No. 120 - CONFORMS TO NSF 7



### Disposal of this appliance after its useful life.

Electric and electronic appliances contain dangerous substances that may have potentially harmful effects for people and the environment. It is recommended to dispose of it properly, DO NOT DISPOSE OF ELECTRICAL OR ELECTRONIC EQUIPMENT WITH OTHER MUNICIPAL WASTE.

## CHAPTER 2 How to use the Operation and Care Manual

This document is an integral part of the machine. Preserve a copy of this operation manual for the entire working life of the appliance even if transferred or sold. Additional copies can be obtained from the manufacturer.

To maintain the operation and care manual in good condition:

1. Use the operation and care manual carefully so as to not damage its contents. In particular, do not leave the operation and care manual around after use and return it to its proper place immediately after consultation.
2. Do not remove, rip out or rewrite parts of the operation and care manual. Any changes to this manual are to be issued by the manufacturer.
3. Keep the operation and care manual in a safe place, away from environmental elements which could damage it.

## CHAPTER 3 Warranty

PrepRite warrants to the original purchaser only that any original part that is found to be defective in material or workmanship will, at PrepRite's option, subject to provisions hereinafter stated, be replaced with a new or rebuilt part. For all other original parts, twenty four (24) months from the date of shipment of appliance. The labor warranty period is twenty four (24) months from the shipping date. PrepRite will bear normal labor charges performed during standard business hours, excluding overtime, holiday rates or any additional fees. To be valid, a warranty claim must be filed during the applicable warranty period. This warranty is not transferable

1. All machine components normally subject to wear and are considered consumables are not included in the warranty: door gaskets, rubber casters, air filter.

2. Possible conditions causing electronic controls to fail include incorrect electrical supply, environmental elements, storms, lightning, water damage, could cause damages which cannot be attributed to the manufacturing company and to the manufacture of the product itself.

3. During the warranty period, for any defect in workmanship and material, all parts and labor will be covered. All warranty claims must be submitted to and conform by all statements and policies of the **Everidge 24/7 Warranty Service.**

4. During the warranty period, we will pay, not to exceed, one (1) hour travel and fifty (50) miles travel. All warranty service will be performed by an authorized service center certified by the manufacturer. All parts replaced under warranty must be returned to the manufacturer for inspection before any warranty is paid.

5. Any components considered defective (door gasket, electronic control, etc.) and is determined to be caused by misuse or abuse during the warranty period will not be considered under warranty. The end user will be responsible for any repairs or parts for repairs.

6. Equipment modified in any manner from original model, substitution of parts other than factory authorized parts, removal of any parts including legs, or addition of any parts.

7. Any losses or damage resulting from malfunction, including loss of product, food product, revenue, or consequential or incidental damages of any kind.

8. Equipment damage caused by accident, shipping, improper installation or alteration.

9. Any injury caused by failure to abide by these written instructions, improper installation, improper electrical connections, alteration to equipment will be the responsibility of the owner.

10. This warranty is exclusive and is in lieu of all other warranties, express or implied, including the implied warranties of merchantability and fitness for a particular purpose. In no event shall PrepRite be liable for loss of use, loss of revenue or profit, or loss of product, or for any indirect, special, incidental, or consequential damages. No person except an officer of PrepRite is authorized to modify this warranty or to incur on behalf of PrepRite any other obligation or liability in connection with PrepRite equipment.

### **End User Obligations**

The end user must immediately inform the manufacturer of any safety system defect and/or any malfunction he or she is aware of.

It is strictly forbidden for the end user and/or any third parties (excluding duly authorized service personnel of the manufacturer) to make modifications of any kind to the appliance, its functions or to this technical publication. In case of malfunctions or defects due to the non-observance of the above, the manufacturing company cannot be held responsible for the consequences.

## **CHAPTER 4 General Safety Precautions**

### **End User Obligations**

1. Never touch the metal parts of the machine with wet or damp hands;
2. Do not pull on the cord to disconnect the plug from the current outlet.
3. Unqualified or untrained personnel are not allowed to use the machine without supervision.
4. Electrical safety of the machine is ensured by a properly grounded electrical circuit, which consists of a grounded cord and cord cap and a correct electrical outlet.
5. The use of an extension cord is not allowed and may result in injury or death.
6. In the event of damage to the cord, the end user of the appliance must not attempt to replace the part. This must be performed by a qualified service personnel.
7. Always switch off and disconnect the appliance from the power supply before beginning any general cleaning or maintenance operation.
8. Clean appliance coating, panels and controls using soft and dry cloths, or cloths slightly soaked in mild detergent solution.

## CHAPTER 5 Installation

Carefully remove the appliance from the carton or crate. Note: Do not discard the carton and other packaging material until you have inspected the unit for hidden damage and tested it for proper operation.



### Warning!

These appliances are heavy and can be easily damaged if not removed from the skid correctly. **DO NOT ATTEMPT** to remove this appliance from the skid by pulling it off or **Extreme** damage will be caused to the base and casters, which **will not be** covered under warranty. Use the proper lifting equipment and protect the base from damage while lifting appliance from the skid. Do not drop appliance on its base or extreme damage will occur.

### Location

To ensure proper operation of this appliance and its components, this appliance must be installed on a stable and level surface, away from high humidity items and excessive heat producing equipment.



**DO NOT** store or use any flammable liquids or allow flammable vapors in the vicinity of this appliance or any other appliance.



**DO NOT** install this appliance in any area where it may be affected by any adverse conditions such as steam, grease, dripping water, high temperatures, etc.



Disconnect the appliance from power before performing any service or maintenance operation which may require parts. This appliance must be grounded properly. If the ground prong is broken, do not use the appliance until it has been repaired or serious injury or death may occur.

These appliances require a dedicated circuit and cannot be plugged into a receptacle that is shared by another appliance or damage to compressor, blown fuses or tripped circuits will be caused, which will not be covered under warranty.



This appliance must have adequate ventilation space to allow heat to be dissipated from the condenser, as well as it needs adequate ventilation to cool the condenser. Do not locate this appliance tight against the wall or against any heat producing device or damage can occur to the unit. **Please allow a minimum or 2" air gap from the back and sides and 12" from the front for adequate ventilation.** In locations with excessive dust, dirt, loose paper, flour or powdery substances, cleaning of the condenser coil may need to be performed on a fairly regular basis. This is the customer's responsibility and must be performed by a qualified service technician or damage to the components can and will occur. Do not use caustic cleaners on the condenser coil as it may cause leaks to the sealed system.

## CHAPTER 6 Understanding the Control

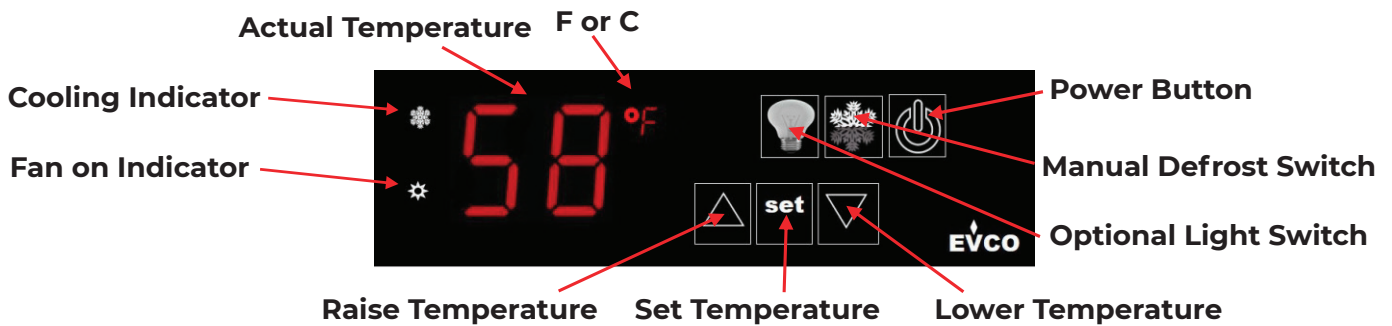

### Operation

Connect the plug to the proper outlet. If it is not the correct outlet, the outlet must be replaced with the correct one by a qualified electrician, as well as ensuring the fuse or breaker is the correct current capacity for the draw of the appliance. Do not use adapters, multiple outlets and/or extension cords. Do not plug in multiple appliances in the same outlet that may exceed current capacity.

1. Turn the unit on by pushing the control on by pushing and holdin the power switch for 2 seconds.
2. To set the cabinet temperature, press the **set** switch and then using the up or down buttons until the desired setting is reached, push the **set** button again.
3. The compressor has a 1 minute delay before it comes on.
4. Once the evaporator coil has reached 40 degrees, the fan(s) will be activated and the cabinet will begin to cool.
5. Allow the cabinet to pre-cool for at least 1 hour before loading in product. If the product is at ambient temperature, the cabinet temperature will rise and it may take a couple of hours to stabilize.
6. Once the temperature inside the cabinet reaches the set temperature, the cooling indicator light will go out, but the fans will continue to run. When the temperature rises, the cooling indicator will turn back on and the compressor will activate to bring the temperature back down to the set point.
7. Do not keep the door(s) open for an extended period of time, as this will cause the temperature to rise rapidly and product will not maintain temperature.
8. To turn the unit off, push and hold the power switch for 2 seconds.

### Cleaning and Maintenance

Use mild cleaning products, such as dish detergent or Pine Sol to clen the unit. Do not use any scouring pads or nylon scrubbers, as this will scratch the surface. Do not flood the compartment with water or use a hose or pressure washer to clean the interior or exterior of the unit, as extreme damage will occur. The use of a stainless steel cleaner and polish can be used on the exterior only.

Ensure the door gaskets are kept clean and if they are ripped or damaged, they must be replaced to maintain proper operation.

## PPT481C Series Prep Table



**Model: PPT481C-4809**  
 · Refrigerated Cabinet  
 · 2 Drawers  
 · Stainless Steel Top (no sides)



**Model: PPT481C-4808**  
 · Refrigerated Cabinet  
 · 2 Drawers  
 · Granite Top Asy



**Model: PPT481C-4805**  
 · Refrigerated Cabinet  
 · 1 Door  
 · Stainless Steel Top



**Model: PPT481C-4800**  
 · Refrigerated Cabinet  
 · No Door  
 · No Top



**Model: PPT481C-4803**  
 · Refrigerated Cabinet  
 · 1 Door  
 · Granite Top Asy



**Model: PPT481C-4804**  
 · Refrigerated Cabinet  
 · 1 Door  
 · Stainless Steel Top (no sides)



**Model: PPT481C-4823**  
 · Refrigerated Cabinet  
 · 2 Drawers  
 · Ambient Dough Drawers  
 · Granite Top Asy  
 · 60" Condiment Rail



**Model: PPT481C-4822**  
 · Refrigerated Cabinet  
 · 1 Door  
 · Ambient Dough Drawers  
 · Granite Top Asy  
 · 60" Condiment Rail



**Model: PPT481C-4819**  
 · Refrigerated Cabinet  
 · 2 Drawers  
 · Ambient Dough Drawers  
 · Stainless Steel Top (no sides)



**Model: PPT481C-4813**  
 · Refrigerated Cabinet  
 · 1 Door  
 · Ambient Dough Drawers  
 · Granite Top Asy



**Model: PPT481C-4815**  
 · Refrigerated Cabinet  
 · 1 Door  
 · Ambient Dough Drawers  
 · Granite Top Asy



**Model: PPT481C-4818**  
 · Refrigerated Cabinet  
 · 2 Drawers  
 · Ambient Dough Drawers  
 · Granite Top Asy



## PPT602C Series Prep Table



**Model: PPT602C-6013**  
 · Refrigerated Cabinet  
 · 4 Drawers  
 · Granite Top Assy



**Model: PPT602C-6010**  
 · Refrigerated Cabinet  
 · 1 Door  
 · 2 Drawers  
 · Stainless Steel Top Assy



**Model: PPT602C-6009**  
 · Refrigerated Cabinet  
 · 1 Door  
 · 2 Drawers  
 · Stainless Steel Top (no sides)



**Model: PPT602C-6008**  
 · Refrigerated Cabinet  
 · 1 Door  
 · 2 Drawers  
 · Granite Top Assy



**Model: PPT602C-6001**  
 · Refrigerated Cabinet  
 · 2 Doors  
 · No Top

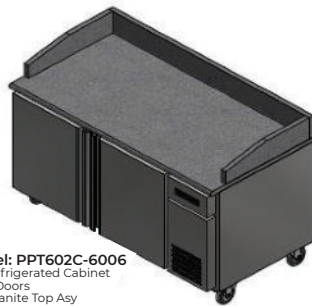

**Model: PPT602C-6006**  
 · Refrigerated Cabinet  
 · 2 Doors  
 · Granite Top Assy



**Model: PPT602C-6006**  
 · Refrigerated Cabinet  
 · 1 Door  
 · 2 Drawers  
 · Stainless Steel Top (no sides)

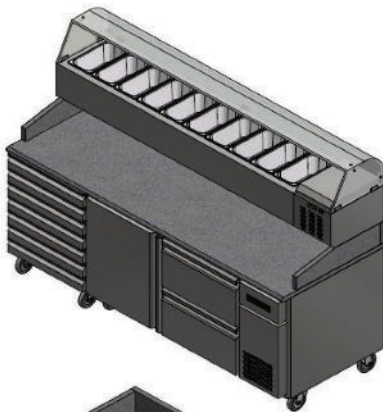

**Model: PPT602C-6035**  
 · Refrigerated Cabinet  
 · 1 Door  
 · 2 Drawers  
 · Ambient Dough Drawers  
 · Granite Top Assy  
 · 84" Condiment Rail



**Model: PPT602C-6023**  
 · Refrigerated Cabinet  
 · 1 Door  
 · 2 Drawers  
 · Ambient Dough Drawers  
 · Stainless Steel Top

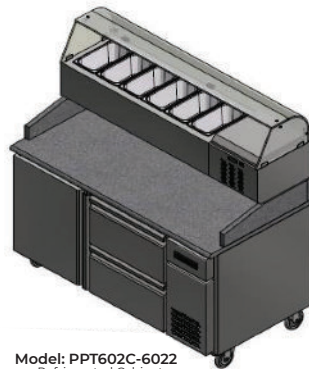

**Model: PPT602C-6022**  
 · Refrigerated Cabinet  
 · 1 Door  
 · 2 Drawers  
 · Granite Top Assy  
 · 60" Condiment Rail



**Model: PPT602C-6022**  
 · Refrigerated Cabinet  
 · 1 Door  
 · 2 Drawers  
 · Ambient Dough Drawers  
 · Granite Top (no sides)



**Model: PPT602C-6018**  
 · Refrigerated Cabinet  
 · 2 Door  
 · Ambient Dough Drawers  
 · Granite Top Assy

## PPT843C Series Prep Table



**Model: PPT843C-8409**  
 · Refrigerated Cabinet  
 · 2 Doors  
 · 2 Drawers  
 · Stainless Steel Top

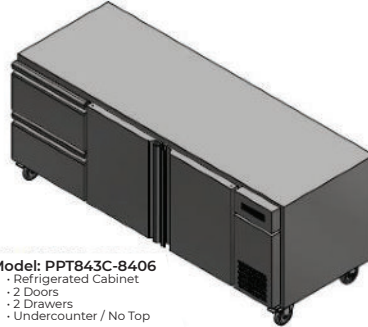

**Model: PPT843C-8406**  
 · Refrigerated Cabinet  
 · 2 Doors  
 · 2 Drawers  
 · Undercounter / No Top

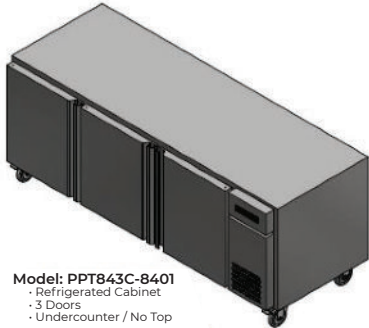

**Model: PPT843C-8401**  
 · Refrigerated Cabinet  
 · 3 Doors  
 · Undercounter / No Top



**Model: PPT843C-8403**  
 · Refrigerated Cabinet  
 · 3 Doors  
 · Granite Top Assy



**Model: PPT843C-8405**  
 · Refrigerated Cabinet  
 · 3 Doors  
 · Stainless Steel Top



**Model: PPT843C-8420**  
 · Refrigerated Cabinet  
 · 2 Doors  
 · 2 Drawers  
 · Granite Top Assy  
 · 84" Condiment Rail



**Model: PPT843C-8419**  
 · Refrigerated Cabinet  
 · 3 Doors  
 · Granite Top Assy  
 · 84" Condiment Rail



**Model: PPT843C-8418**  
 · Refrigerated Cabinet  
 · 6 Drawers  
 · Stainless Steel Top



**Model: PPT843C-8415**  
 · Refrigerated Cabinet  
 · 1 Door  
 · 4 Drawers  
 · Stainless Steel Top



**Model: PPT843C-8413**  
 · Refrigerated Cabinet  
 · 1 Door  
 · 4 Drawers  
 · Granite Top Assy

## PPT481C Exploded Views

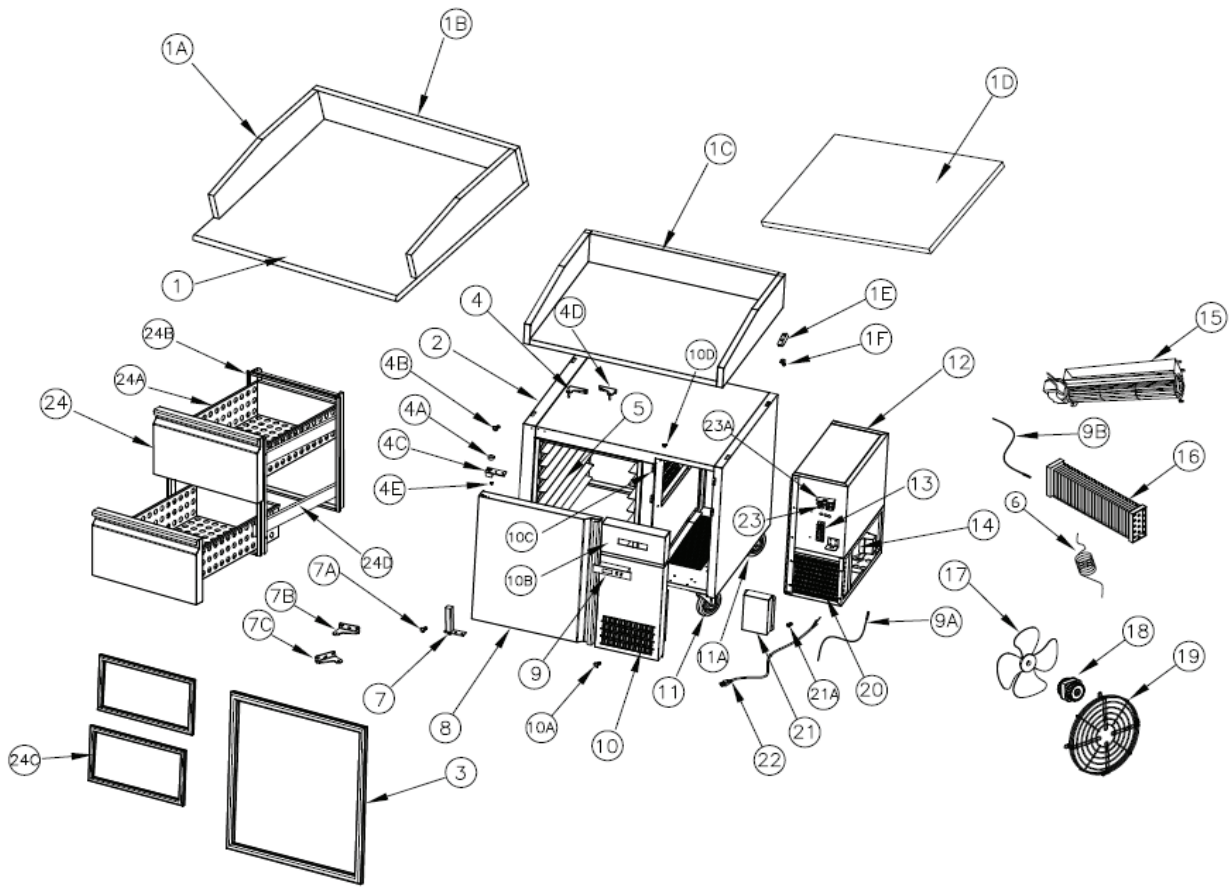

Number	Description	Part Number	Quantity
1	Granite Table Top	CT-3001	1
1A	Granite Table Top Side Splash	CT-3002	2
1B	Granite Table Top Back Splash	CT-3003	1
1C	Stainless Steel Countertop w/ splash (Optional)	CT-3004	1
1D	Stainless Steel Countertop Flat (Optional)	CT-3005	1
1E	Stainless Steel Countertop Mounting Brackets	BK-2001	4
1F	Countertop Mounting Bracket Screws	SC-100005	8
2	Cabinet Body	CH-3006	1
3	Door Gasket	GS-7001	1
4	Upper Door Hinge Left Head	HG-8005	1
4A	Upper Door Hinge Bearing	HG-8002	1
4B	Upper Door Hinge Screw	SC-100001	2
4C	Upper Door Hinge Insert	HG-8004	1
4D	Upper Door Hinge Right Hand	HG-8001	1
4E	Upper Door Hinge Insert Screw	SC-100006	2

<b>5</b>	Side Rack Assembly	SH-100002	1
<b>6</b>	Capillary Tube	RE-90001	1
<b>7</b>	Lower Door Spring Hinge	HG-8002	1
<b>7A</b>	Lower Door Spring Hinge Screw	SC-100006	2
<b>7B</b>	Lower Door Spring Hinge Mounting Bracket Left Hand	HG-8003	1
<b>7C</b>	Lower Door Spring Hinge Mounting Bracket Right Hand	HG-8006	1
<b>8</b>	Door Assembly (No Gasket)	DR-4001	1
<b>9</b>	Controller (EVR234N9)	CN-3007	1
<b>9A</b>	Condenser Probe	PR-70002	1
<b>9B</b>	Evaporator Probe	PR-70001	1
<b>10</b>	Condenser Louvered Panel	PR-70003	1
<b>10A</b>	Condenser Louvered Panel Screw	SC-100004	2
<b>10B</b>	Control Panel	PR-70004	1
<b>10C</b>	Condenser and Control Panel	BK-2001	4
<b>11</b>	Caster, Swivel	BK-3008	2
<b>11A</b>	Caster, Fixed	BK-3009	2
<b>12</b>	Refrigeration Assembly Complete	RE-90002	1
<b>13</b>	Terminal Strip	TM-200001	1
<b>14</b>	Compressor Whirlpool FFI12HBX	RE-90003	1
<b>15</b>	Evaporator Fan Assembly	FN-6001	1
<b>16</b>	Evaporator Coil	RE-90004	1
<b>17</b>	Condenser Fan Blade	FN-6002	1
<b>18</b>	Condenser Fan Motor	FN-6003	1
<b>19</b>	Condenser Fan Motor Guard/Holder	GU-7002	1
<b>20</b>	Condenser Coil	RE-90005	1
<b>21</b>	Electrical Box Cover	PN-70005	1
<b>22</b>	Power Cord	CD-3010	1
<b>23</b>	Fuse 20A	FN-6004	2
<b>23A</b>	Fuse Holder 30A	FN-6005	1
<b>24</b>	Drawer Front Panel (Optional)	DR-4003	2
<b>24A</b>	Drawer Assembly (Optional)	DR-4002	2
<b>24B</b>	Drawer Cartridge Complete (Optional)	DR-4004	1
<b>24C</b>	Drawer Gasket (Optional)	GS-7003	2
<b>24D</b>	Drawer Rails	DR-4005	4

## PPT602C Exploded Views

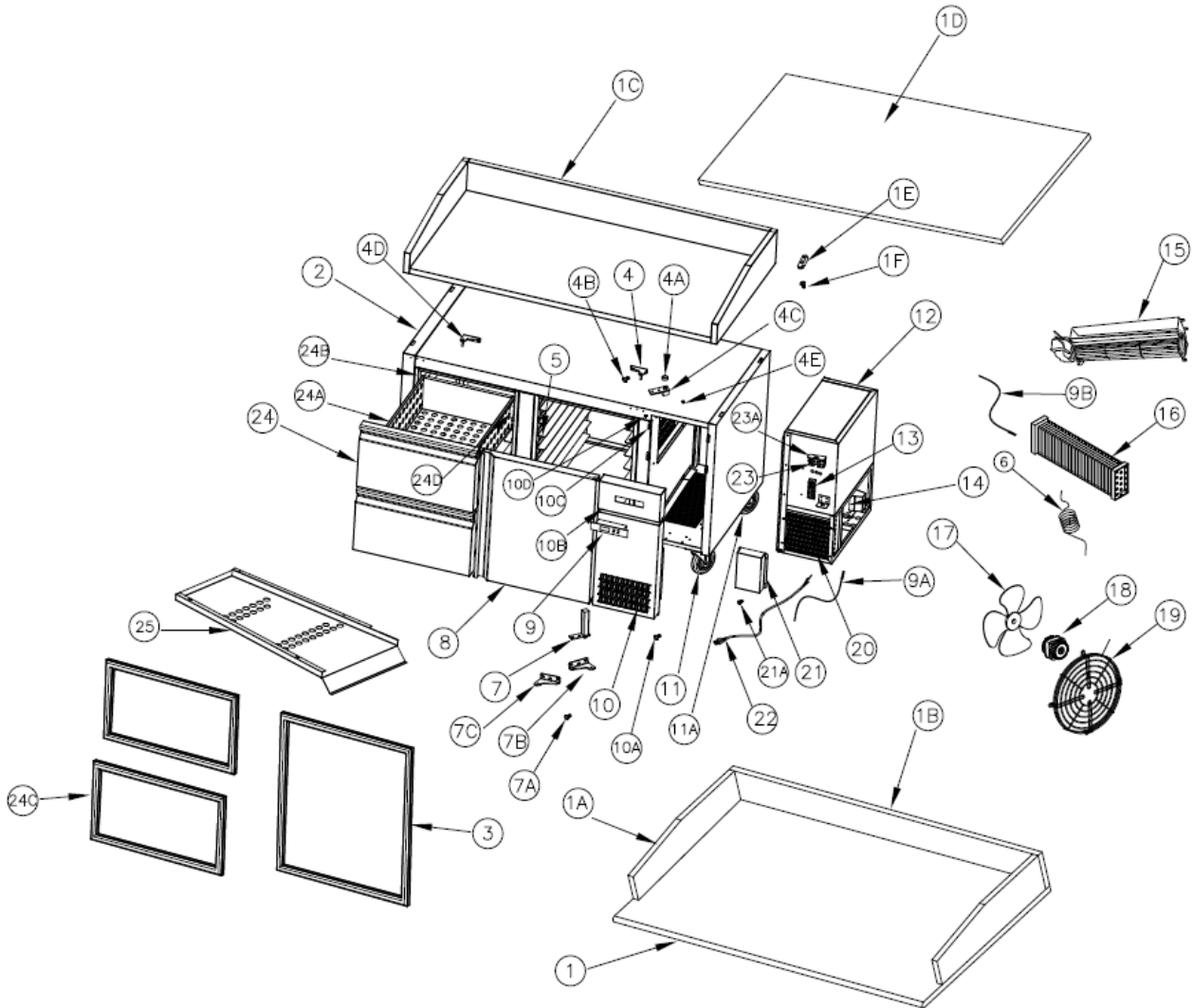

Number	Description	Part Number	Quantity
1	Granite Countertop (Main Flat)	CT-3011	1
1A	Granite Countertop Side Splash	CT-3002	2
1B	Granite Countertop Back Splash	CT-3012	1
1C	Stainless Steel Countertop w/ splash	CT-3013	1
1D	Stainless Steel Countertop Flat (Optional)	CT-3014	1
1E	Countertop Mounting Brackets	BK-2001	4
1F	Countertop Mounting Bracket Screw	SC-100005	8
2	Main Chassis	CH-3015	1
3	Door Gasket	GS-7001	2
4	Upper Door Hinge Left Head	HG-80015	2
4A	Upper Door Hinge Bearing	HG-8002	2

<b>4B</b>	Upper Door Hinge Screw	SH-100001	4
<b>4C</b>	Upper Door Hinge Insert	HG-8004	2
<b>4D</b>	Upper Door Hinge Left Hand	HG-8005	2
<b>4E</b>	Upper Door Hinge Insert Screw	SC-100006	4
<b>5</b>	Side Rack Assembly	SH-100002	2
<b>6</b>	Capillary Tube	RE-90001	1
<b>7</b>	Lower Door Spring Hinge	HG-8002	2
<b>7A</b>	Lower Door Spring Hinge Screw	SC-100006	4
<b>7B</b>	Lower Door Spring Hinge Bracket Right Hand	HG-8003	2
<b>7C</b>	Lower Door Spring Hinge Bracket Right Hand	HG-8006	2
<b>8</b>	Door Assembly (No Gasket)	DR-4001	2
<b>9</b>	Controller (EVR234N9)	CN-3007	1
<b>9A</b>	Condenser Probe	PR-70002	1
<b>9B</b>	Evaporator Probe	PR-70001	
<b>10</b>	Condenser Louver Panel	PR-70003	1
<b>10A</b>	Condenser Louver Panel Screw	SC-100003	2
<b>10B</b>	Control Panel	PR-70004	1
<b>10C</b>	Condenser and Control Panel Bracket	BK-2001	4
<b>11</b>	Caster, Swivel	CN-3008	2
<b>11A</b>	Caster, Fixed	CN-3009	2
<b>12</b>	Refrigeration Assembly Complete	RE-90004	1
<b>13</b>	Terminal Strip	TM-200001	1
<b>14</b>	Compressor Whirlpool FFI12HBX	RE-90003	1
<b>15</b>	Evaporator Fan Assembly	GU-6001	1
<b>16</b>	Evaporator Coil	RE-90004	1
<b>17</b>	Condenser Fan Blade	FN-6002	1
<b>18</b>	Condenser Fan Motor	FN-6003	1
<b>19</b>	Condenser Motor Mount/Guard	GU-7002	1
<b>20</b>	Condenser Coil	RE-90005	1
<b>21</b>	Electrical Cover	PN-70005	1
<b>22</b>	Power Cord 16A	CD-3010	1
<b>23</b>	Fuse 20A	FU-6004	2
<b>23A</b>	Fuse Holder	FU-6005	1
<b>24</b>	Drawer Front Panel (Optional)	DR-4003	2 or 4
<b>24A</b>	Drawer Assembly (Optional)	DR-4002	2 or 4
<b>24B</b>	Drawer Cartridge Complete (Optional)	DR-4004	1 or 2
<b>24C</b>	Drawer Gasket (Optional)	GS-7003	2 or 4
<b>24D</b>	Drawer Rail (Optional)	DR-4005	2 or 8
<b>25</b>	Internal Air Baffle	DN-70006	1

## PPT843C Exploded Views

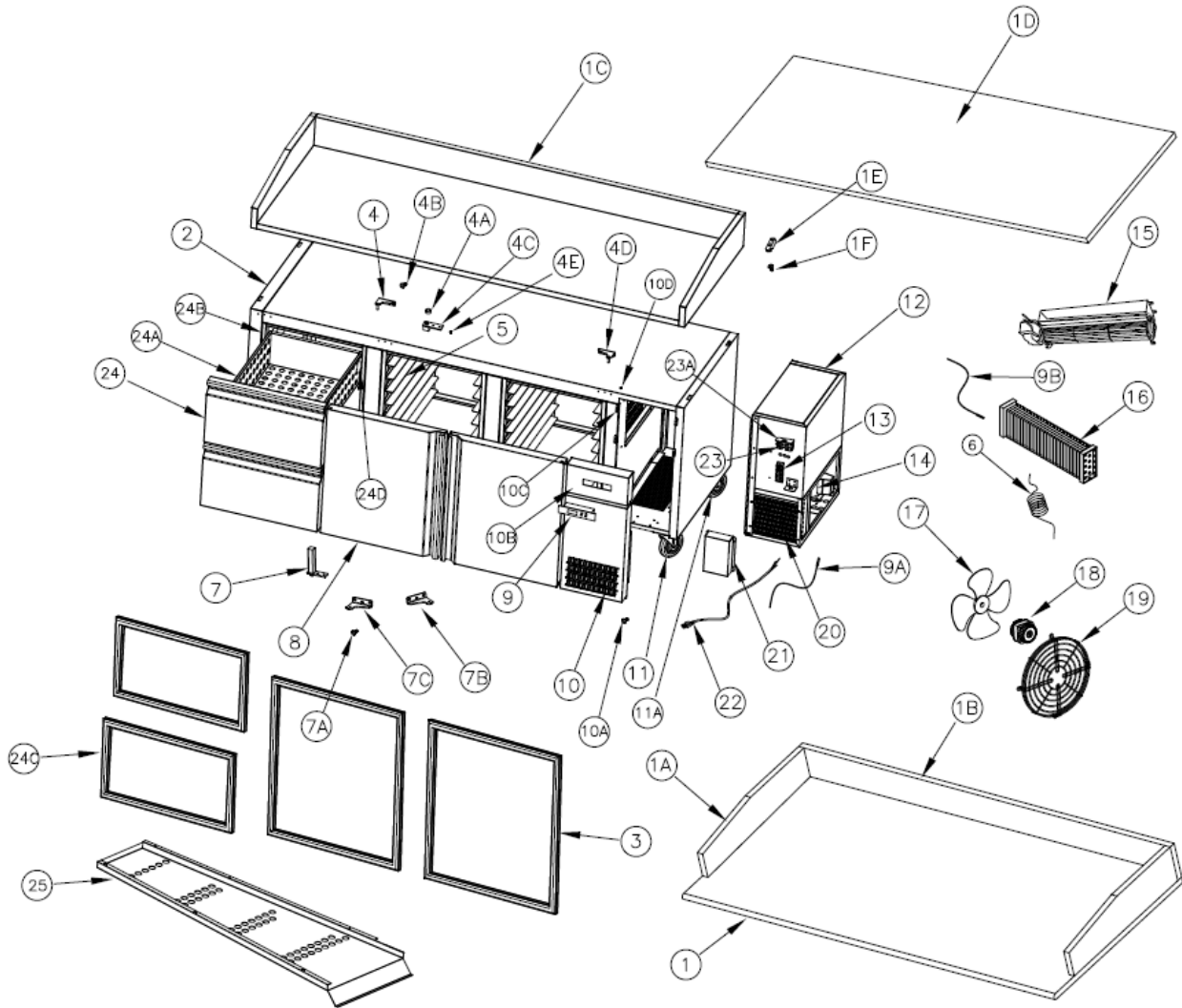

Number	Description	Part Number	Quantity
1	Granite Countertop (Main Flat)	CT-3016	1
1A	Granite Countertop Side Splash	CT-3002	2
1B	Granite Countertop Back Splash	CT-3003	1
1C	Stainless Steel Countertop w/ Splashes	CT-3004	1
1D	Stainless Steel Countertop Flat	CT-3005	1
1E	Countertop Mounting Brackets	BK-2001	4
1F	Countertop Mounting Bracket Screws	SC-100005	8
2	Main Chassis	CH-3006	1
3	Door Gasket	GS-7001	3
4	Upper Door Hinge Left Head	HG-8005	3
4A	Upper Door Hinge Bearing	HG-8002	3
4B	Upper Door Hinge	SC-100001	6

<b>4C</b>	Upper Door Hinge Insert	SH-100001	4
<b>4D</b>	Upper Door Hinge Right Hand	HG-8004	2
<b>4E</b>	Upper Door Hinge Insert Screw	HG-8005	2
<b>5</b>	Side Rack Assembly	SC-100006	4
<b>6</b>	Capillary Tube	SH-100002	2
<b>7</b>	Lower Door Spring Hinge	RE-90001	1
<b>7A</b>	Lower Door Spring Hinge Screw	HG-8002	2
<b>7B</b>	Lower Door Spring Hinge Bracket Right Hand	SC-100006	4
<b>7C</b>	Lower Door Spring Hinge Bracket Left Hand	HG-8003	2
<b>8</b>	Door Assembly (No Gasket)	HG-8006	2
<b>9</b>	Control (EVR234N9)	DR-4001	2
<b>9A</b>	Condenser Probe	CN-3007	1
<b>9B</b>	Evaporator Probe	PR-70002	1
<b>10</b>	Condenser Louver Panel	PR-70001	
<b>10A</b>	Condenser Louver Panel Screw	PR-70003	1
<b>10B</b>	Control Panel	SC-100003	2
<b>10C</b>	Condenser and Control Panel Bracket	PR-70004	1
<b>10D</b>	Condenser and Control Panel Bracket Screw	BK-2001	4
<b>11</b>	Caster, Swivel	CN-3008	2
<b>11A</b>	Caster, Fixed	CN-3009	2
<b>12</b>	Refrigeration Assembly Complete	RE-90004	1
<b>13</b>	Terminal Strip	TM-200001	1
<b>14</b>	Compressor Whirlpool FFI12HBX	RE-90003	1
<b>15</b>	Evaporator Fan Assembly	GU-6001	1
<b>16</b>	Evaporator Assembly	RE-90004	1
<b>17</b>	Condenser Fan Blade	FN-6002	1
<b>18</b>	Condenser Fan Motor	FN-6003	1
<b>19</b>	Condenser Fan Motor Mount/Guard	GU-7002	1
<b>20</b>	Condenser Assembly	RE-90005	1
<b>21</b>	Electrical Cover	PN-70005	1
<b>21A</b>	Electrical Panel Screw	CD-3010	1
<b>22</b>	Power Cord 16A	FU-6004	2
<b>23</b>	Fuse 20A	FU-6005	1
<b>23A</b>	Fuse Holder	DR-4003	2 or 4
<b>24</b>	Drawer Front Panel (Optional)	DR-4002	2 or 4
<b>24A</b>	Drawer Assembly (Optional)	DR-4004	1 or 2
<b>24B</b>	Drawer Cartridge Complete (Optional)	GS-7003	2 or 4
<b>24C</b>	Drawer Gasket (Optional)	DR-4005	2 or 8
<b>24D</b>	Drawer Rail (Optional)	DN-70006	1
<b>25</b>	Internal Air Baffle (Not Shown)	DN-70006	1



## PAD7 Exploded Views

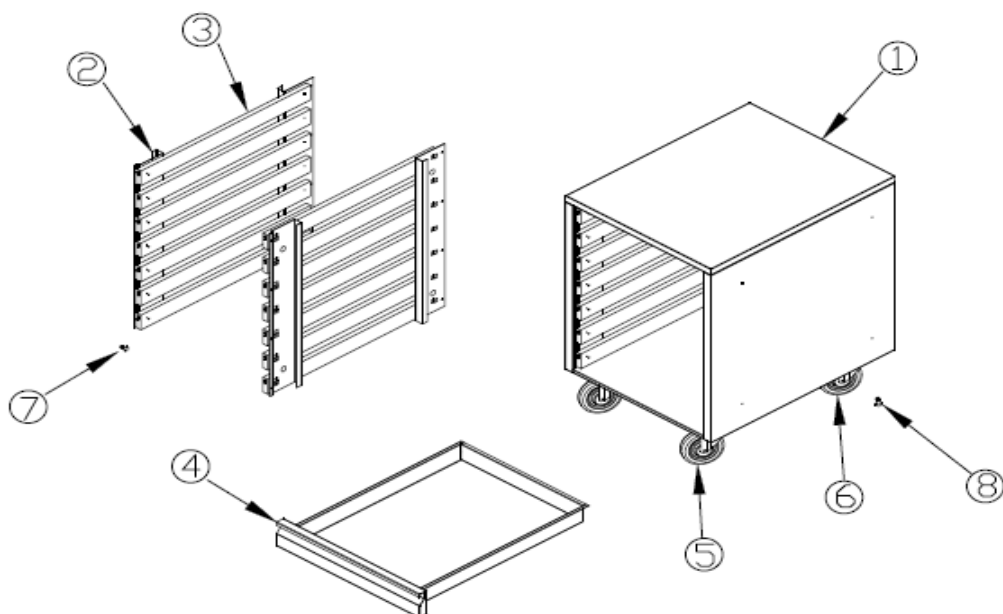

Number	Description	Part Number	Quantity
1	Main Chassis	CH-3023	1
2	Drawer Side Rail Frame	DR-100009	2
3	Drawer Rail	DR-4005	14
4	Drawer Complete	DR-4006	7
5	Caster, Swivel	CS-3008	2
6	Caster, Fixed	CS-3009	2
7	Screw	SC-100001	8
8	Caster Bolt	SC-10010	16

## PPT481C, PPT602C, PPT843C Wiring Diagram

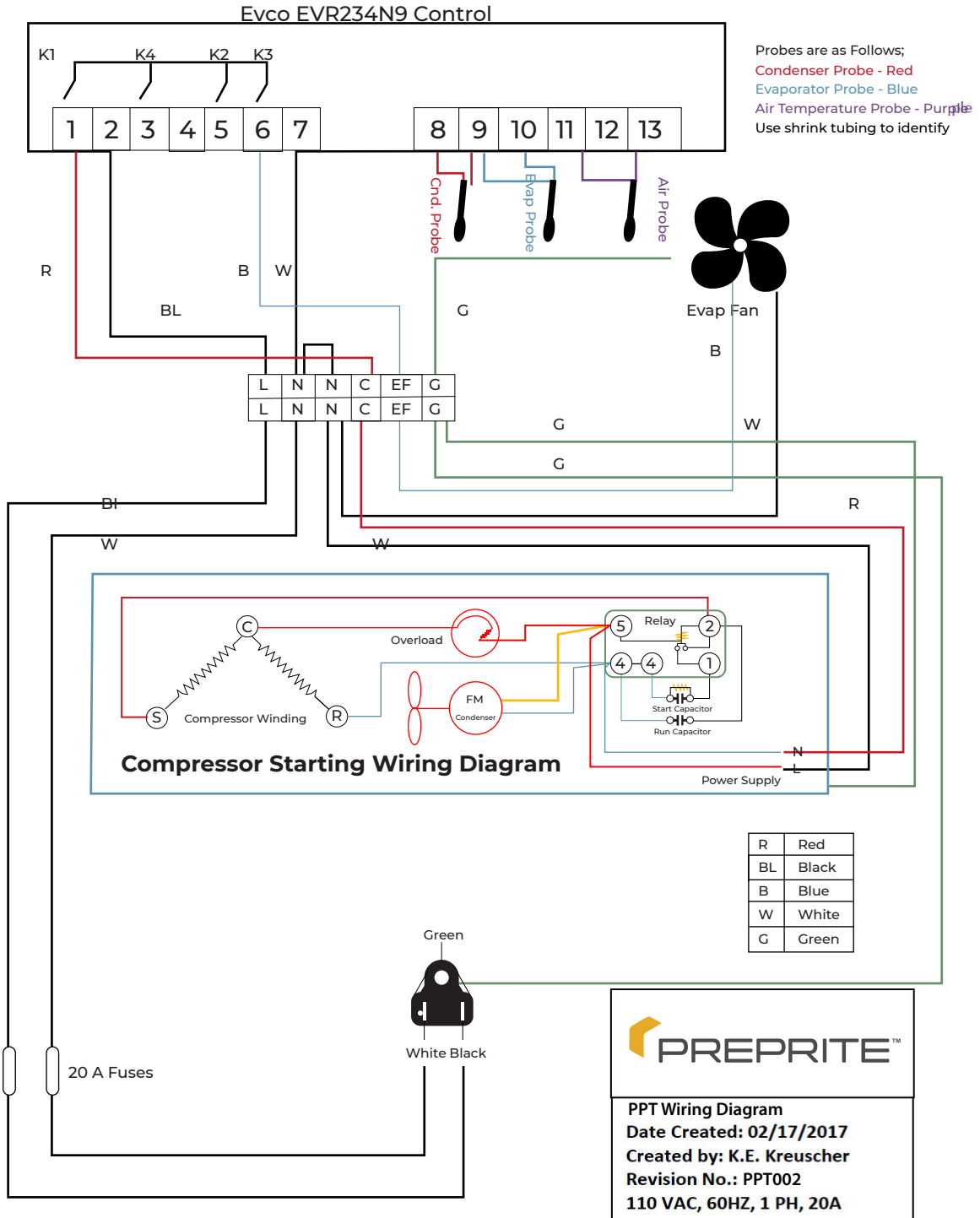



# NOTES:



 CROWNTONKA®  ICS®  LOTEMP DOORS®  PREPRITE®  THERMALRITE®

Walk-In Coolers/Freezers • Restoration & Replacement Doors  
Cook-Chill Specialty Solutions • Parts, Service & Warranty • Construction Services

Proud to be family-owned.



15600 37th Ave N • Suite 100 • Plymouth, Minnesota 55446 • 888-227-1629 • Everidge.com • info@everidge.com