

Installation Manual
Manually Operated Cold Storage Doors
With Wall Guide

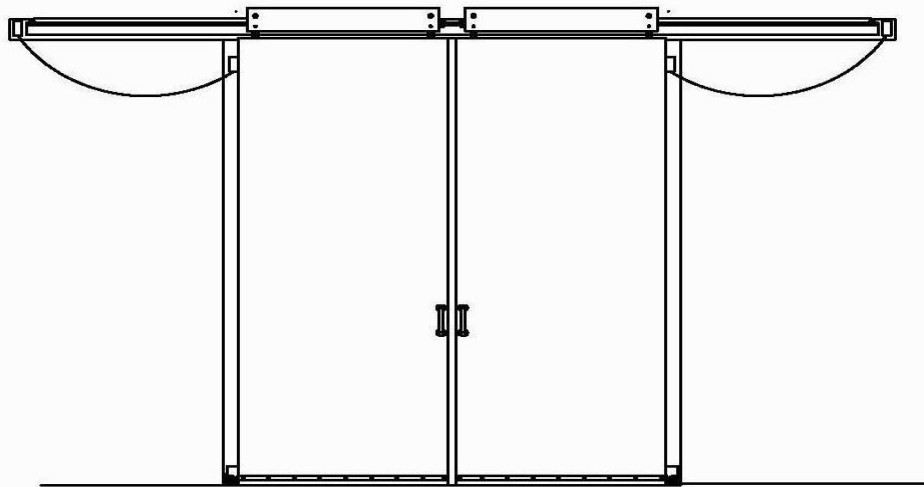

Model DHM Shown

For Model :

SHM – Single Horizontal Manual

DHM – Double Horizontal Manual

Revised: 10 October 2022

IMPORTANT

THIS DOOR ASSEMBLY HAS BEEN CUSTOM DESIGNED AND MANUFACTURED FOR THIS OPENING. REVIEW INSTALLATION INSTRUCTIONS THOROUGHLY **BEFORE** INSTALLING DOOR UNIT.

**DO NOT ATTEMPT TO
ALTER, CUT, MODIFY, REMOVE,
DIS-ASSEMBLE AND RE-ASSEMBLE
OR RE-MANUFACTURE
ANY COMPONENT
FROM IT'S ORIGINAL FACTORY CONDITION!**

**ANY MODIFICATION TO THIS DOOR ASSEMBLY
WILL VOID THE WARRANTY IN IT'S ENTIRETY!**

Table of Contents

INTRODUCTION	1
GENERAL ARRANGEMENT	2
SECTION 1	
HEADER AND VERTICAL CASINGS	3
SECTION 2	
DOOR ASSEMBLY	5
SECTION 3	
DOOR PLACEMENT	6
SECTION 4	
DOOR AND BOTTOM SEAL ADJUSTMENT	7
SECTION 5	
DOOR SEAL ADJUSTMENT/ WALL GUIDE INSTALLATION	8
SECTION 6	
HEATING CABLES	10

The following are general arrangement illustrations to aid you with device locations and terminology.

BIPART DOOR

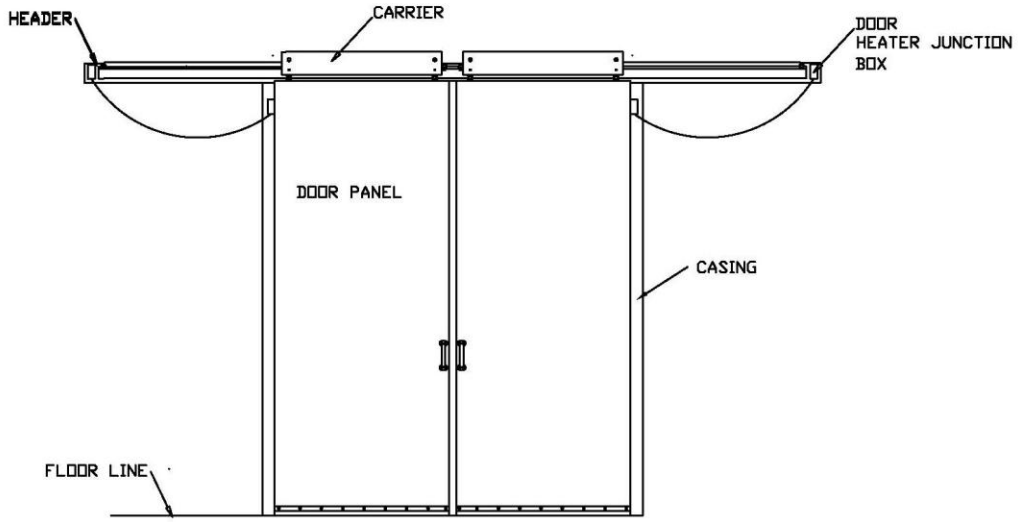

SINGLE SLIDE DOOR

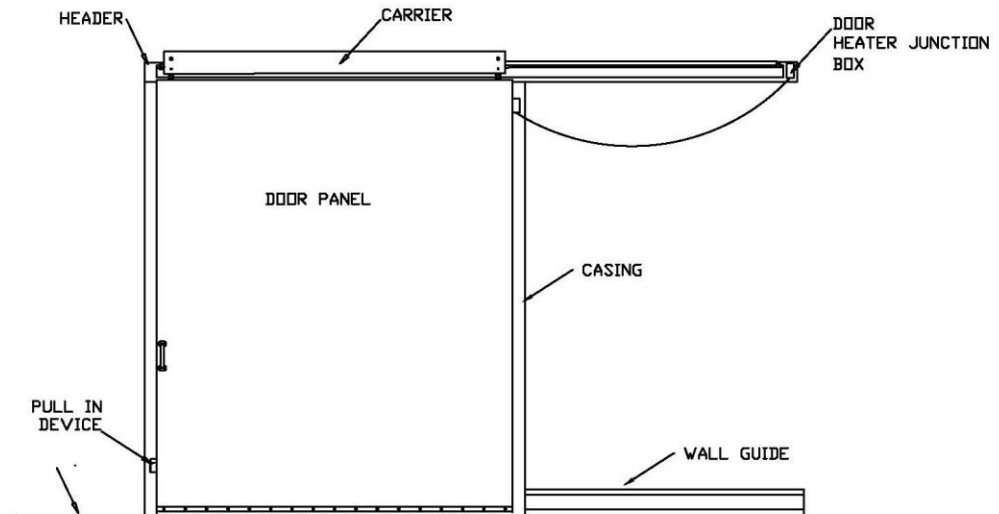

Section
1

HEADER AND VERTICAL CASINGS

This Section will discuss how to properly set up and install the Header and Vertical Casings to prepare to hang the horizontal sliding door.

The casings must be plumb and parallel. If the floor slopes, start by setting the casing on the high side first. Shim to raise the other casing so that the top of the casing is level. If wall is not plumb, shim as shown below.

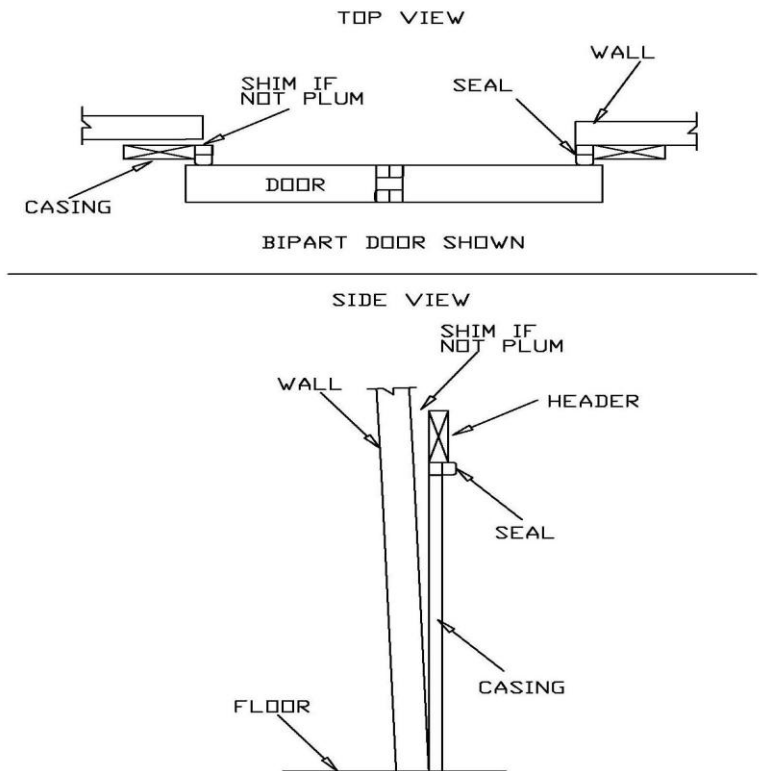

Plumb casing as shown and attach securely to wall using fasteners through holes pre-drilled

SINGLE AND DOUBLE HORIZONTAL SLIDE

The header must be plumb and level on the same plane as the casings. Shimming the header might be required to set it on the same plane as the casings. Install entire header on top of vertical casings using fasteners through holes provided in header casing. Tighten all fasteners on casings and header. Re-check to see that complete assembly is plumb and level.

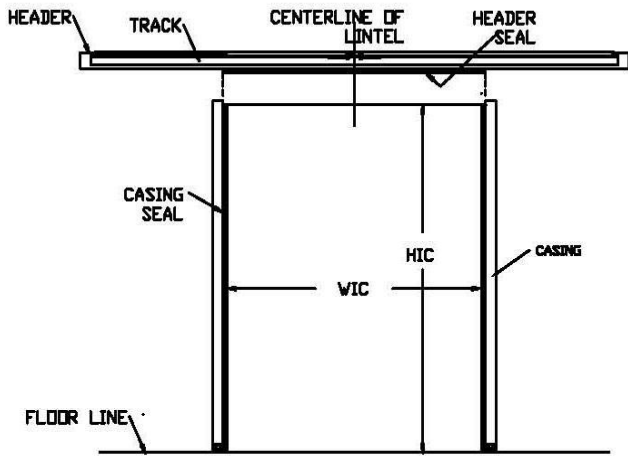

BIPART DOOR

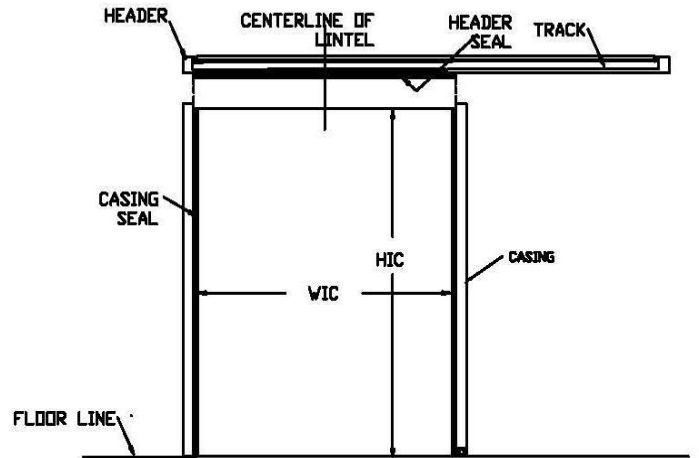

RIGHT SLIDE DOOR SHOWN

NOTE: If back-up header and casings or jamb covers are required, install as illustrated below.

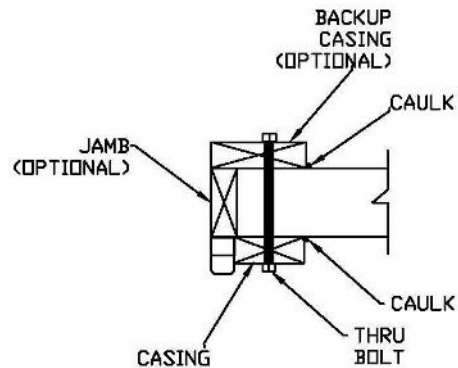
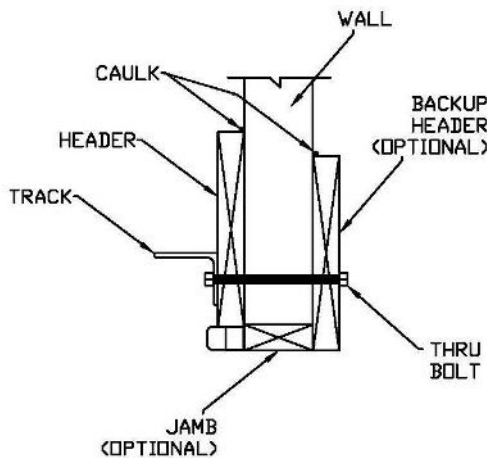

Use sealant to provide vapor seal between header, casings and wall. Compliance with above is essential to assure proper contact between door and gaskets. Seal and attach securely

DOOR(S) ASSEMBLY

This Section will discuss how to properly assemble and install the multiple door panels. (Not required on single doors without spine seal.

If door is larger than SHS 8'0" x 10'0" or DHS 16'0" x 10'0" door may be 2-piece construction requiring the individual sections to be bolted to securing angles and plates. The illustration below shows an example of a single and a double horizontal slide, and how to attach the securing angles and plates. Use the hardware provided to fasten the securing angles and plates to the door sections.

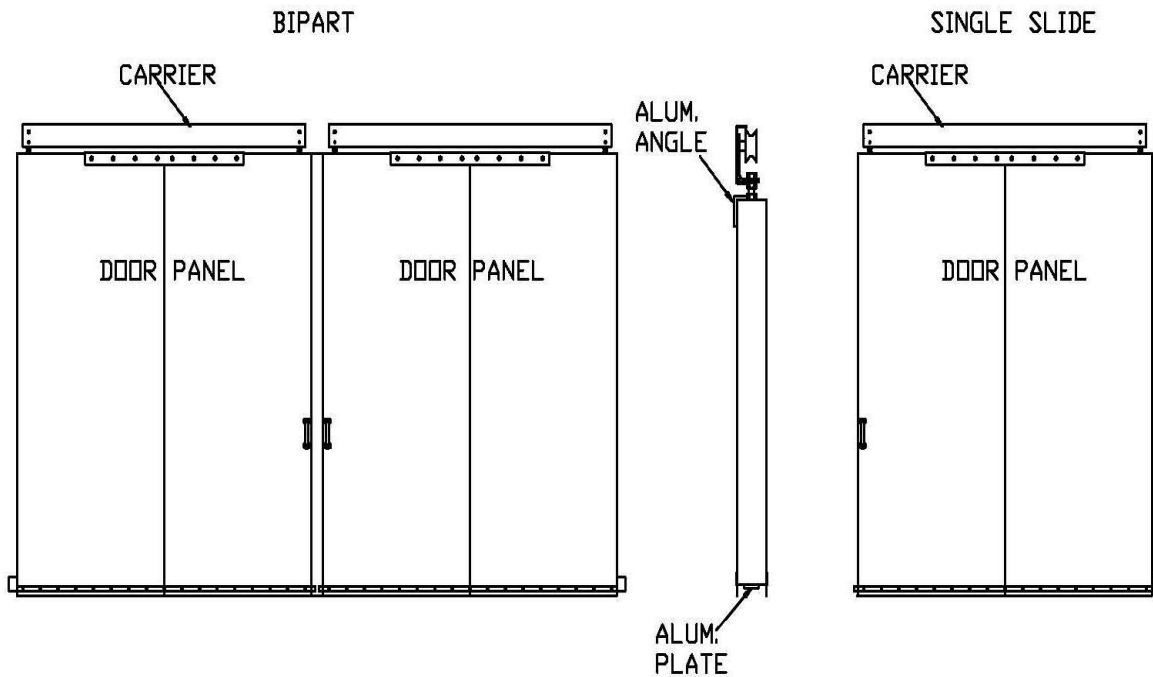

Once the securing angles and plates are attached to the door sections the door(s) is now ready to be attached to the door carrier. The door carriers simply bolt to the top of the door panel(s). Locate the threaded holes in the top of the door panel(s) and thread the adjustment nut into the threaded holes.

NOTE: Make sure that the vertical side of the door carrier faces the trackside of the door panel(s).

DOOR(S) PLACEMENT

This Section will discuss how to properly install the door panels and how to hang the horizontal sliding door.

To hang the door position the door panel(s) so the wheels are at the track ramps. These are located at the top of the track, where the carrier wheels would rest if the door is in the closed position. Once the door(s) are located in front of the closed position remove the wheels from the carrier by removing the wheel bolt and lock washer

NOTE: The leading and trailing edge wheels are not the same and MUST be placed back in the same location as they were when shipped.

Once the wheels are removed from the carrier, move the door(s) toward the header and re-install the wheels. **Make sure that the wheel bolts are tight.** The illustration below shows the doors of a double horizontal slide with the leading and trailing edge wheels installed on the track correctly

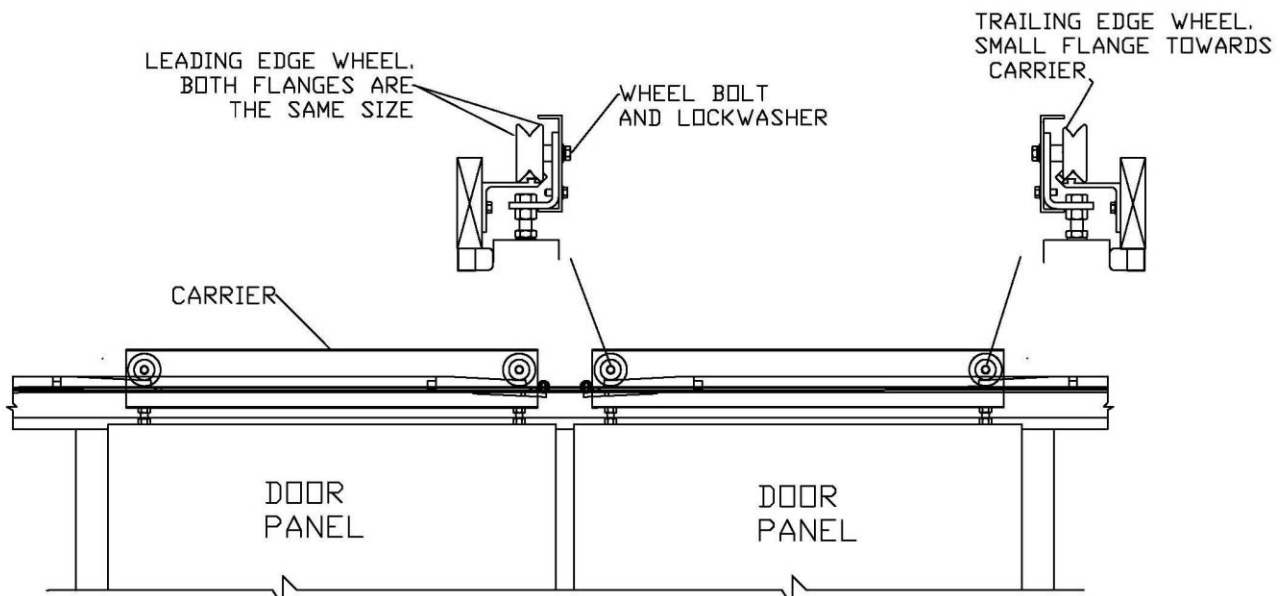

Once the door(s) are hung slide the door(s) back and forth to the open and closed positions to ensure that there are free from obstructions and there and there are no obstructions.

Also ensure that the wheels drop down the wheel ramps.

DOOR AND BOTTOM SEAL ADJUSTMENT

This Section will discuss how to properly adjust the doors vertical height to adjust the bottom door seal to minimize cold air leakage.

The bottom seal should just contact the floor with a slight crush or bend to seal. To achieve this loosen the lower nut. Rotate the adjustment nut right to lower or left to raise the door. Once the door is at the required level tighten the lower nut. Proceed with the next adjustment screw adjustment if necessary, making sure that the leading edge of the door panel is plumb and perpendicular to the header when finished.

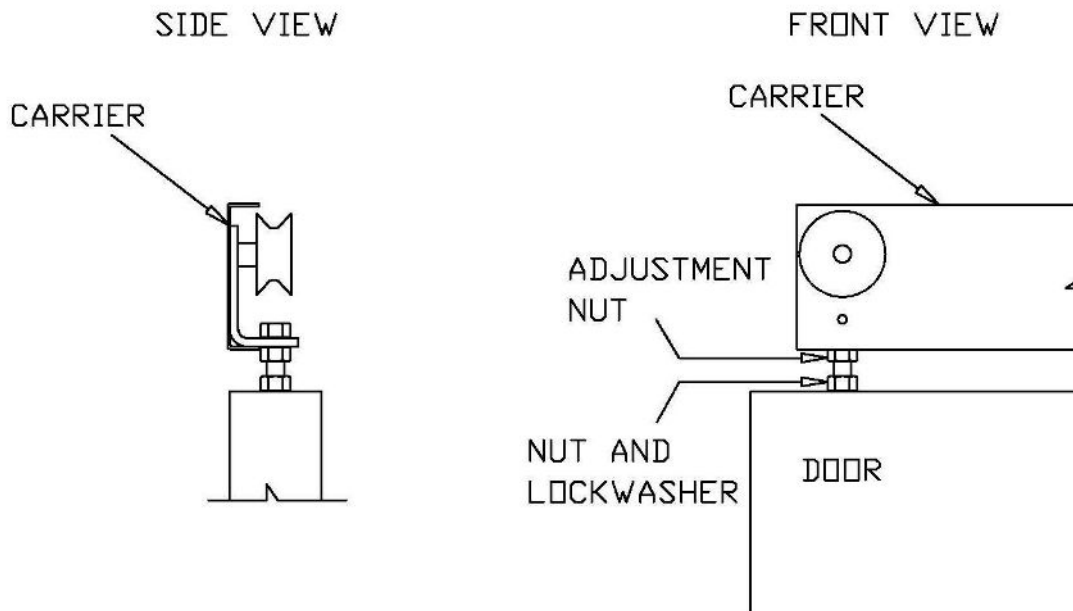

Now, check to see if the bottom seal is now depressed, approximately 1/8" evenly.

Section
5

DOOR SEAL ADJUSTMENT

This Section will discuss how to adjust the door seal between the vertical casings, header and the door(s).

The door(s) panel is held against the vertical casings and the header by the track on top and pull in devise and wall guide at the bottom of the door. A reinforced door seal fills the gap between the door panel and the vertical casings, and the header. The door panel should depress the door seal approximately 1/8". If it is not then the door seal must be adjusted. To adjust the door seals, place the door(s) in closed position, loosen seal attachment screw on seal(s) not making contact with door. Pull the rubber seal towards door until a door seal compression of 1/8" is achieved. Retighten all door seal attachment screws. Proceed to next location requiring adjustment.

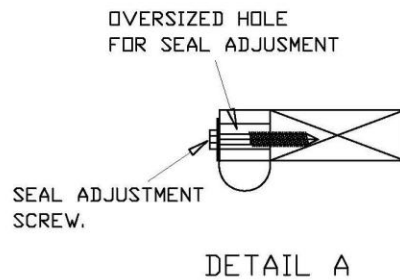
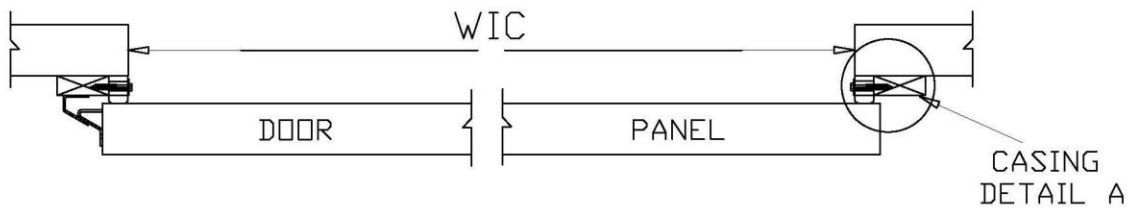

SINGLE AND DOUBLE HORIZONTAL SLIDE

Wall guide installation – position wall guide assy and back up flush to casing and floor, drill 3/8” holes approx 3” in from each end and 2 equally spaced for a total of 4 holes. Attach to wall with 3/8” threaded rod/ nuts/washers. As door opens the door ramp will travel up the casing ramp and along the wall guide maintaining the correct distance outward.

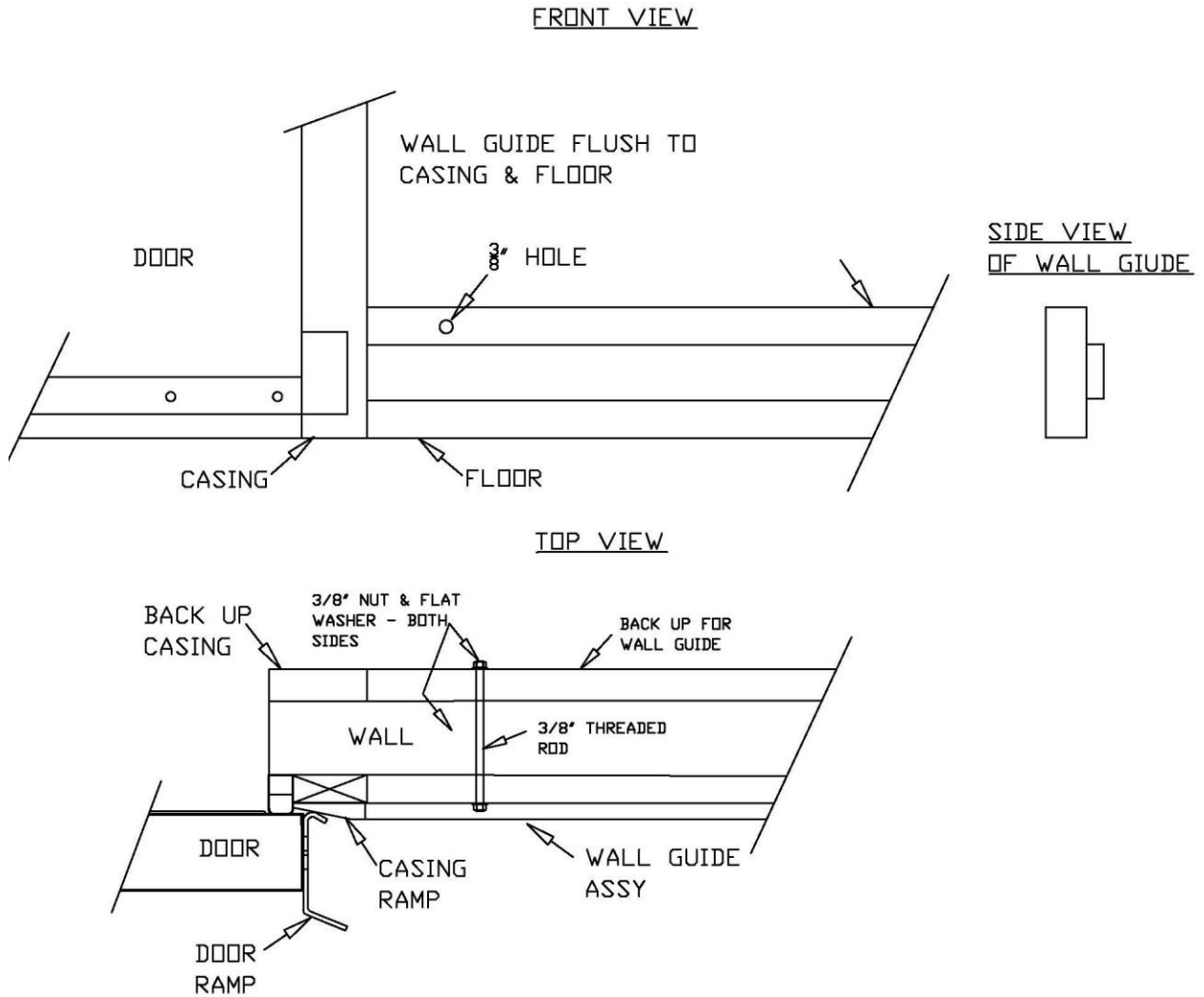

NOTE: If seals need to be re-adjusted, re-caulk around casings and header as required.

Section
6

HEATING CABLES

This Section will discuss the electrical wiring of the freezer door heating cables.

The heating cables are only installed on freezer doors, this is to provide a thermal barrier the door panel and the seals. An additional heat source may be required for excessively temperatures; optional heated seals will provide enough heat to create that thermal barrier.

Insert electrical cables on door(s) into junction box on header see illustration below. Match wires black with black, white with white and green with green. Secure with wire nuts located inside the junction box.

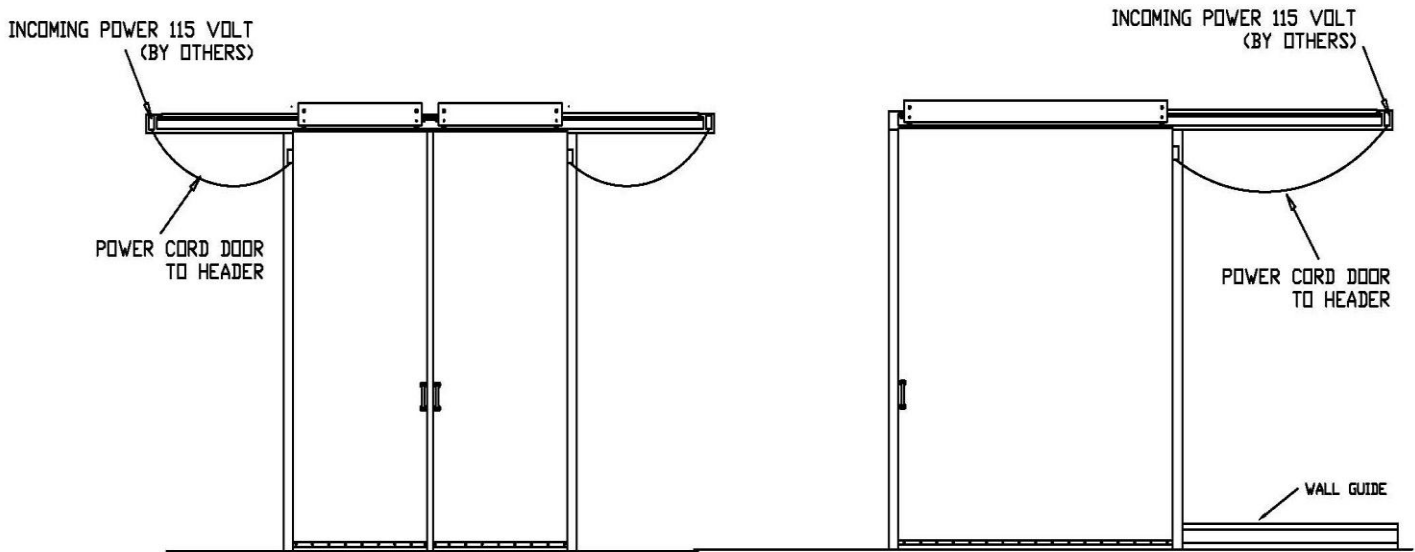

NOTES:



 CROWNTONKA®  ICS™  LOTEMP DOORS™  PREPRITE®  THERMALRITE®

Proud to be family-owned.