

Installation Manual Manually Operated Cold Storage Doors

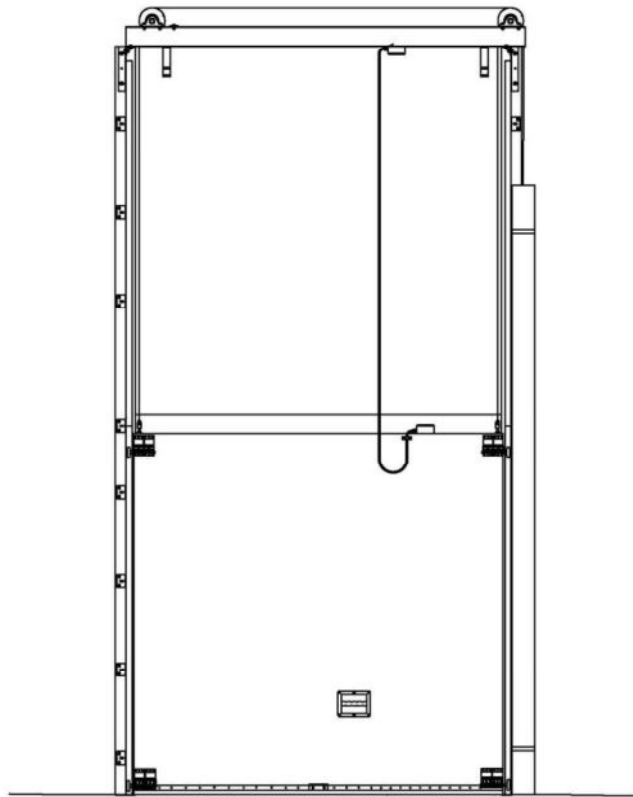

Model SVM Shown

For Model :

SVM – Single Vertical Manual

Revised: 10 October 2022

IMPORTANT

THIS DOOR ASSEMBLY THIS DOOR ASSEMBLY HAS BEEN CUSTOM DESIGNED AND MANUFACTURED FOR THIS OPENING. REVIEW INSTALLATION INSTRUCTIONS THOROUGHLY **BEFORE** INSTALLING DOOR UNIT.

DO NOT ATTEMPT TO ALTER, CUT, MODIFY, REMOVE, DIS-ASSEMBLE AND RE-ASSEMBLE OR RE-MANUFACTURE ANY COMPONENT FROM IT'S ORIGINAL FACTORY CONDITION!

ANY MODIFICATION TO THIS DOOR ASSEMBLY WILL VOID THE WARRANTY IN IT'S ENTIRETY!

Table of Contents

Introduction / TOC	1
General Arrangement diagram	2
S E C T I O N 1	
HEADER AND VERTICAL CASINGS	3
S E C T I O N 2	
DOOR ASSEMBLY	6
S E C T I O N 3	
DOOR PLACEMENT	7
S E C T I O N 4	
COUNTER WEIGHT INSTALLATION AND ADJUSTMENT	8
S E C T I O N 5	
DOOR AND BOTTOM SEAL ADJUSTMENT	10
S E C T I O N 6	
DOOR SEAL ADJUSTMENT	11
S E C T I O N 7	
DOOR HEATING CABLE & OPTIONAL HEATED SEALS	12
S E C T I O N 8	
PREVENTIVE MAINTENANCE	14

SINGLE VERTICAL SLIDE

The following are general arrangement illustrations to aid you with device locations and terminology.

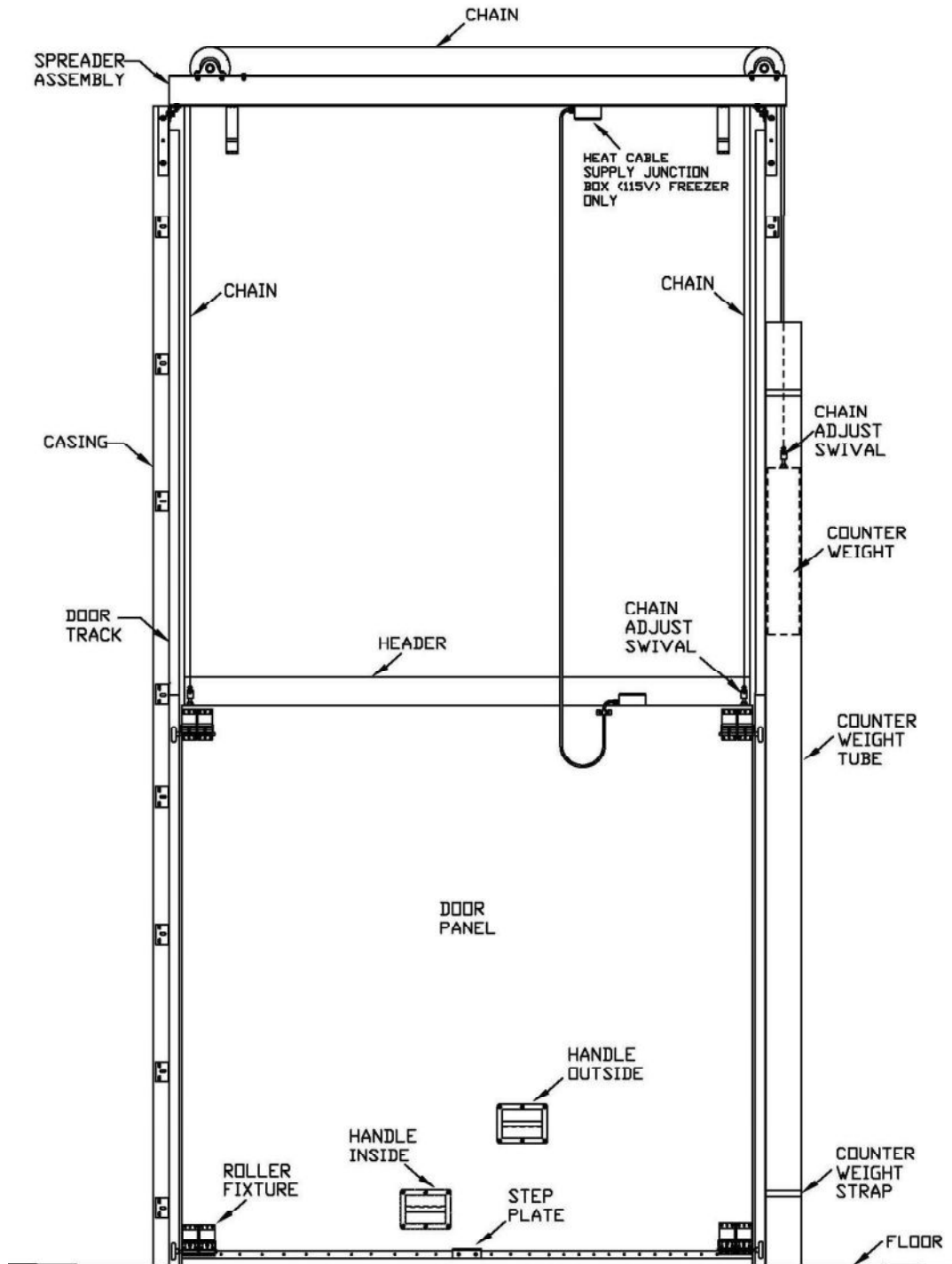

HEADER AND VERTICAL CASINGS

This Section will discuss how to properly set up and install the Spreader Assembly, Header and Vertical Casings to prepare to hang the vertical sliding door.

The casings must be plumb and parallel. If the floor slopes, start by setting the casing on the high side first. Shim to raise the other casing so that the top of the casings are level. If wall is not plumb, shim as required.

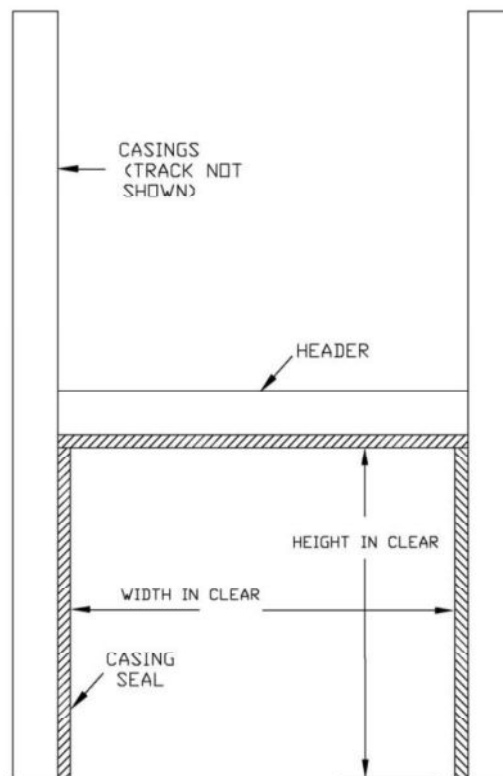

Plumb casing as shown and attach securely to wall using 3/8" threaded rod, washers and nuts through 1 hole in the track brackets on casings.

SINGLE VERTICAL SLIDE

Attach the spreader assembly to the top track brackets using the bolts provided.

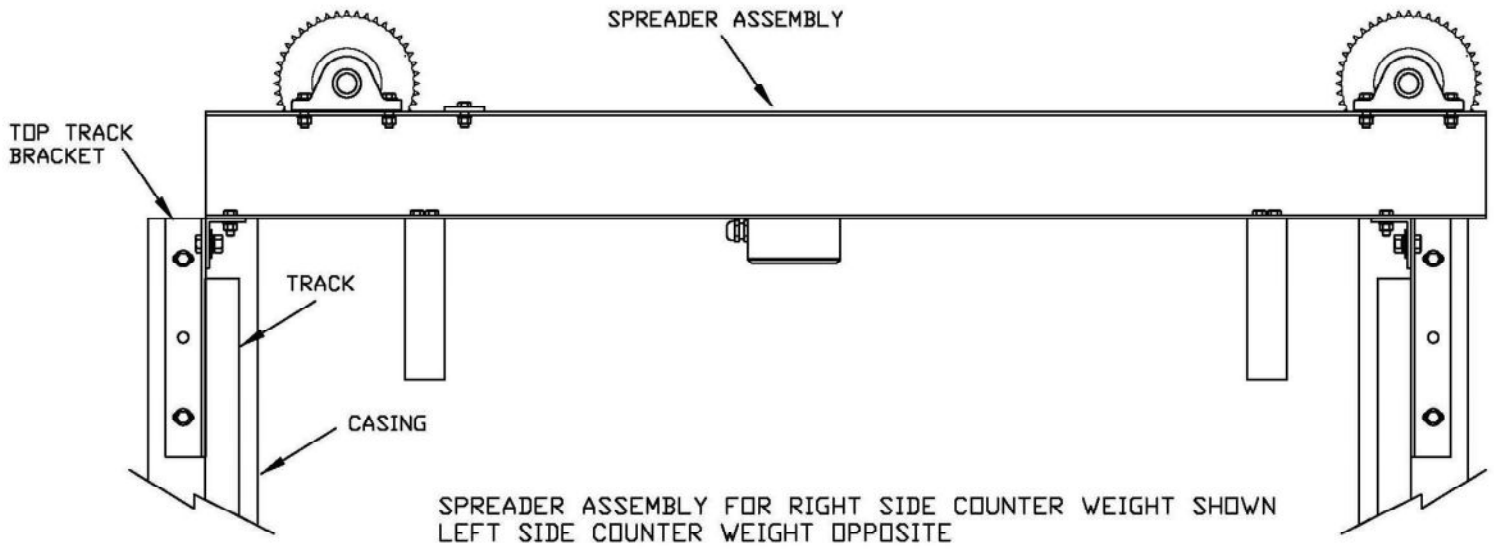

Note: Tighten all fasteners on casings header and spreader assembly.

SINGLE VERTICAL SLIDE

NOTE: If the optional back-up header and casings or jamb covers are required, install as illustrated below.

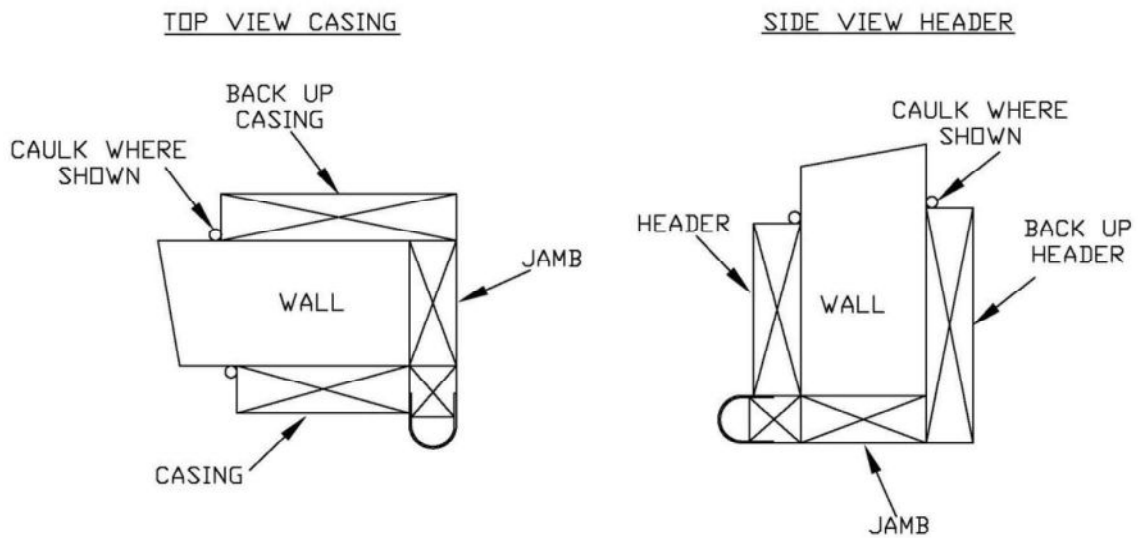

Use sealant to provide vapor seal between header, casings and wall. Compliance with above is essential to assure proper contact between door and gaskets. Seal and attach securely

DOOR ASSEMBLY

This Section will discuss how to properly assemble and install the multiple door panels. (Not required on single doors without spine seal.)

If door is larger than SVS 8'0" x 10'0" door may be 2-piece construction requiring the individual sections to be bolted using a securing angle and plate. The illustration below shows an example of a single vertical slide, and how to attach the securing angle and plate. Use the hardware provided to fasten the securing angle and plate to the door sections.

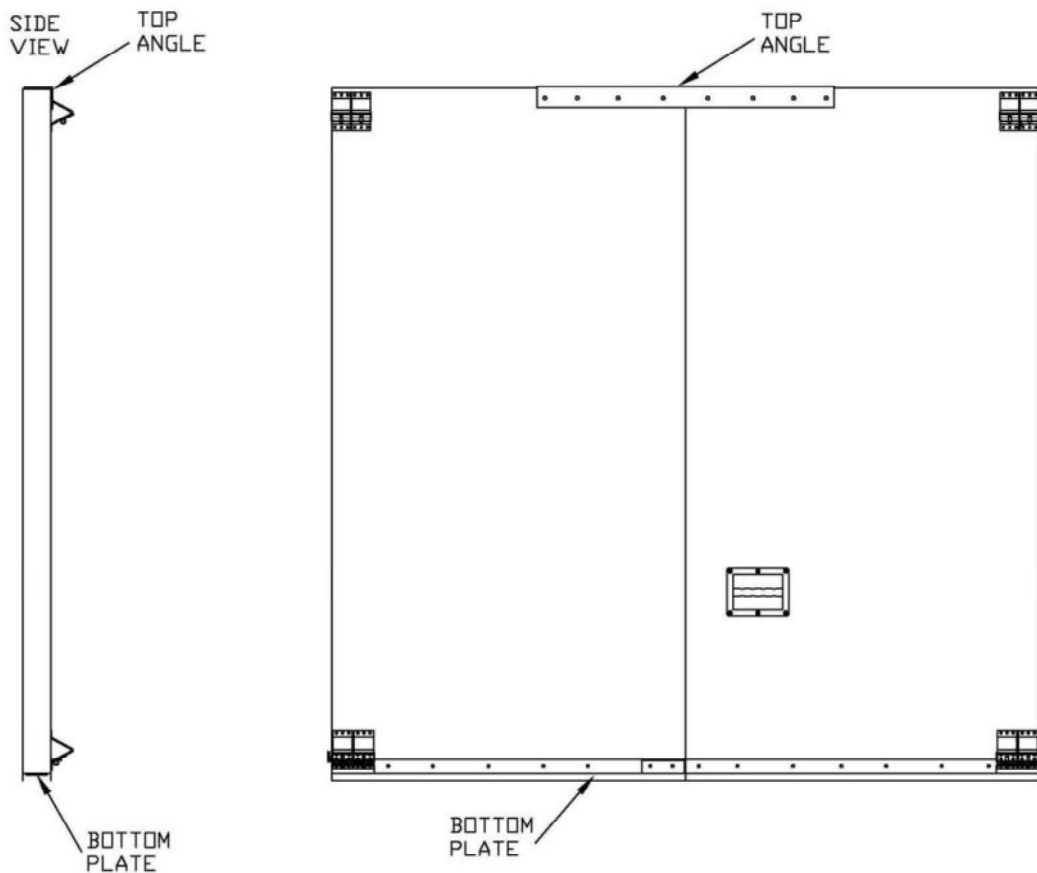

Once the securing angle and plate are attached to the door sections the door is now ready to be inserted into the vertical door track.

DOOR PLACEMENT

This Section will discuss how to properly install the door panels and how to hang the vertical sliding door.

To hang the door, remove the counter weight tube from casing then unbolt the lower right hand track from the casing. Install two rollers in the roller fixtures in each side of the door panel. Position the door panel vertically, and place the left side rollers into the left track, as illustrated below. With the left rollers placed in the left track, place the right track over the right side rollers and pivot the door and track towards the wall as shown. Maintaining the same dimension from the edge of the casing to the track bracket re-fasten the right track to the right side casing.

The illustration below shows the door of a single vertical slide with the rollers installed, and the right lower right track removed for installation.

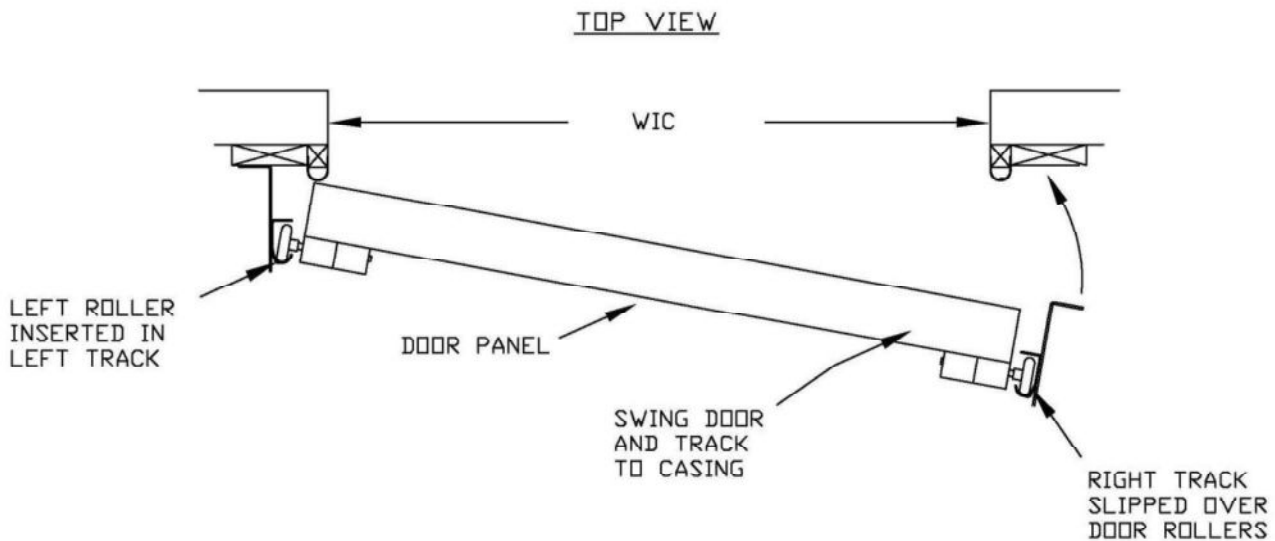

Once the right track is slipped over the door rollers, pivot the entire assembly and secure the right track onto the right hand casing. Note: the track bracket must be reattached in the same location from the edge of the casing to the bracket as removed to maintain equal distance between the left and right tracks.

Section
4

COUNTERWEIGHT INSTALLATION AND ADJUSTMENT

This Section will discuss how to install the door counterweight and how to properly adjust the height to achieve the full operational door height.

Once the door is installed in the track and attached to the casings, locate the lifting chain assemblies in hardware box – one will be labeled “WEIGHT SIDE CHAIN ASSY” and the other “OPPOSITE SIDE CHAIN ASSY” screw one end of the chain adjust to a minimum of 1 1/2” into threaded holes on top of door section . Then lift the chains upward and over their respective sprockets on spreader as illustrated below.

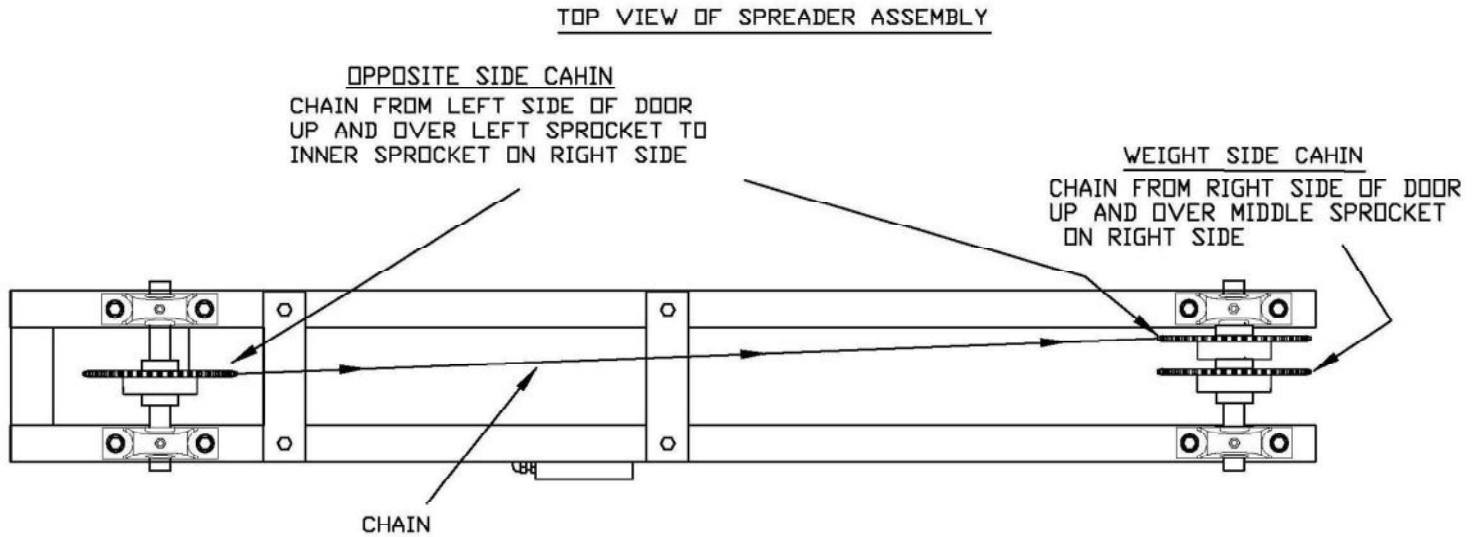

NOTE: CHAIN DIRECTION FOR A RIGHT
COUNTER WEIGHT SHOWN
LEFT COUNTER WEIGHT OPPOSITE

SINGLE VERTICAL SLIDE

Attach the counterweight to the end of each chain to a minimum of 1 1/4" into the counter weight. Counter weight should rest approx 12" higher than the door opening height. Make sure that counterweight is hanging plumb so that each chain carries half the load.

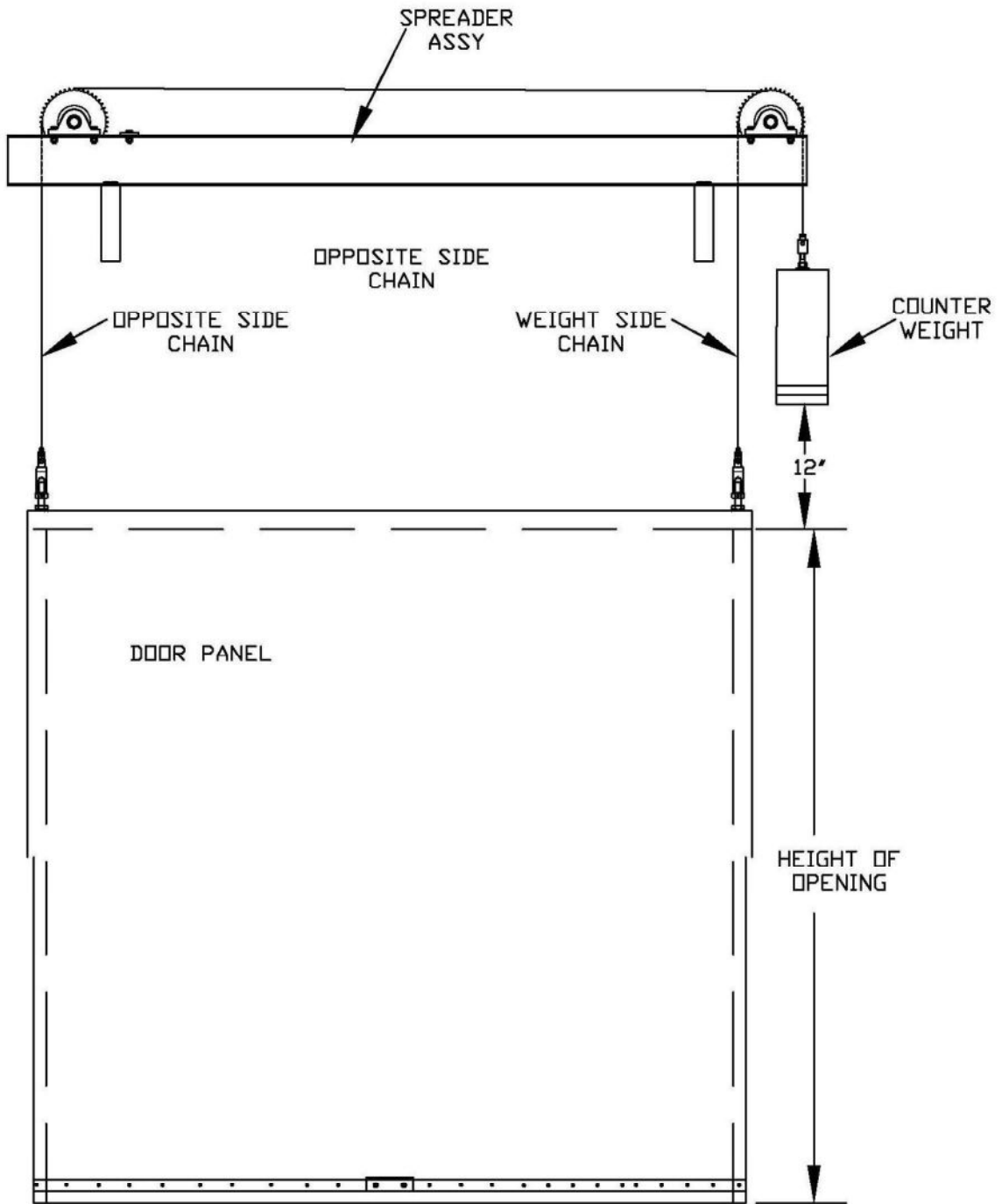

RIGHT COUNTER WEIGHT SHOWN
LEFT COUNTER WEIGHT OPPOSITE

DOOR AND BOTTOM SEAL ADJUSTMENT

This Section will discuss how to properly adjust the doors vertical height, to adjust the bottom door seal and minimize cold air leakage.

The bottom seal should just contact the floor with a slight crush or bend to seal. To achieve this there are two chain adjust swivel, which can be used to adjust, the chain from either the side of the door. With the door in the closed position adjust the door height so that the bottom seal compresses against the floor approximately $\frac{1}{8}$, to accomplish this, rotate the chain adjust swivel clockwise to raise the door and counter clockwise to lower the door. Confirm that the door panel is horizontal and the seal is compressed against the floor evenly. When all of the chain adjustments are made tighten the nuts on all four chain adjust swivels to prevent them from working loose. Replace counter weight tube.

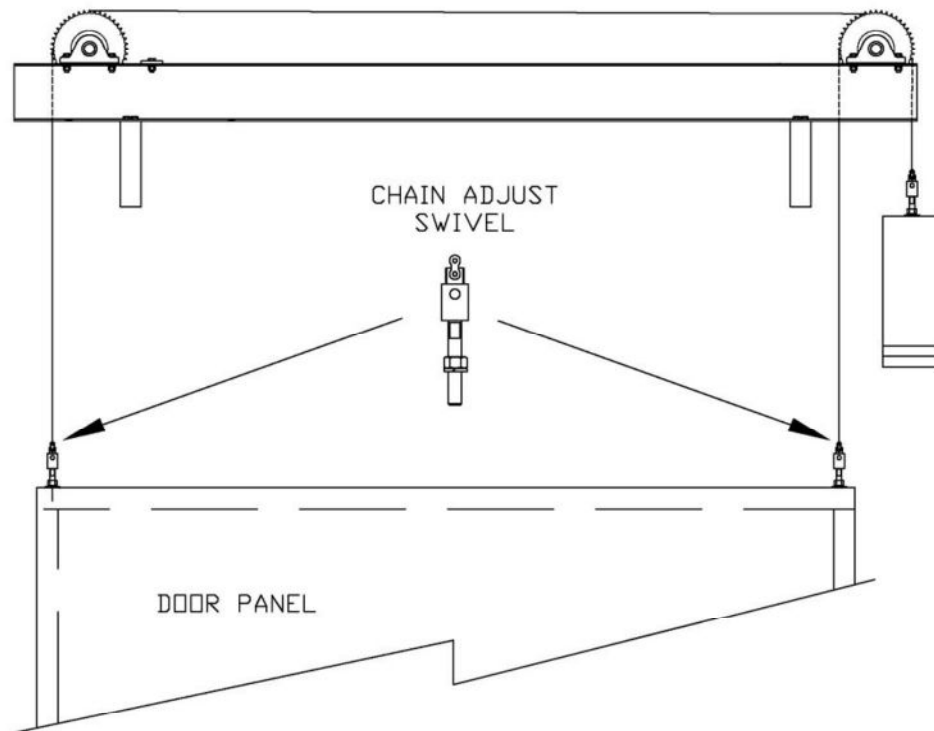

DOOR SEAL ADJUSTMENT

This Section will discuss how to adjust the door seal between the vertical casings, header and the door.

The door panel is held against the vertical casings and the header by the track. A reinforced door seal fills the gap between the door panel and the vertical casings, and the header the door panel should depress the door seal approximately 1/8". If it is not then the door seal must be adjusted. To adjust the door seals, place the door in closed position, loosen seal attachment screw on seal(s) not making contact with door. Move seal towards door until a door seal compression of 1/8" is achieved. Retighten all door seal attachment screws. Proceed to next location requiring adjustment.

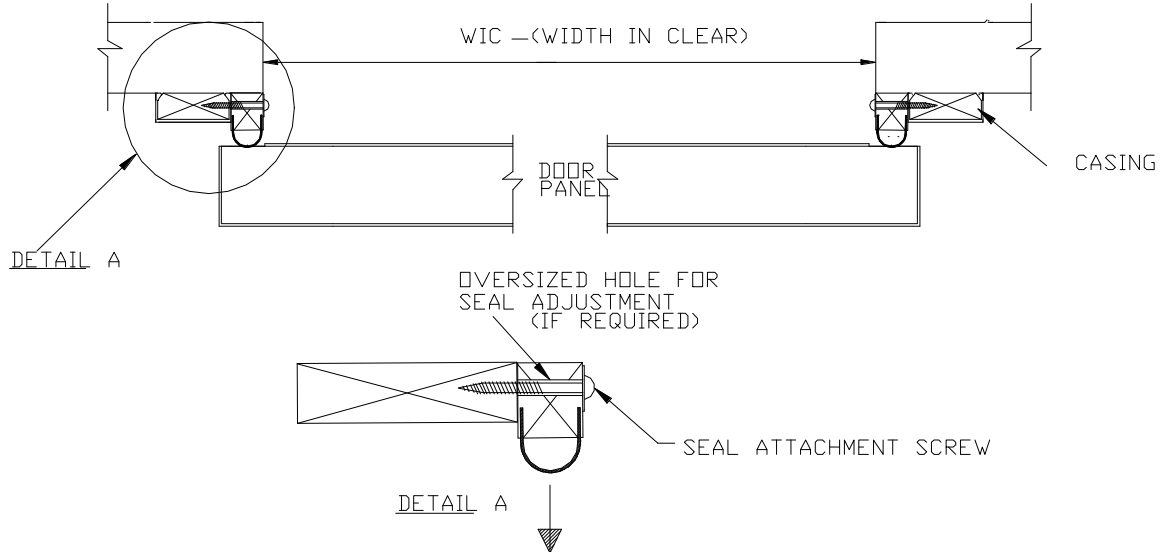

NOTE: If seals need to be re-adjusted, re-caulk around casings and header as required.

DOOR HEATING CABLE & OPTIONAL HEATED SEALS

This Section will discuss the electrical wiring of the freezer door heating cables and the optional heated seals.

The heating cables are only installed on freezer doors, this is to provide a thermal barrier the door panel and the seals. An additional heat source may be required for excessively temperatures; optional heated seals will provide enough heat to create that thermal barrier.

The power source to the heating source needs to be supplied from an alternate power source; this allows the control power for the door to be switched off when required (i.e. for service) without removing the power supply to the door heaters. This will ensure that the heated door seals remain pliable and continue to seal out the cold air.

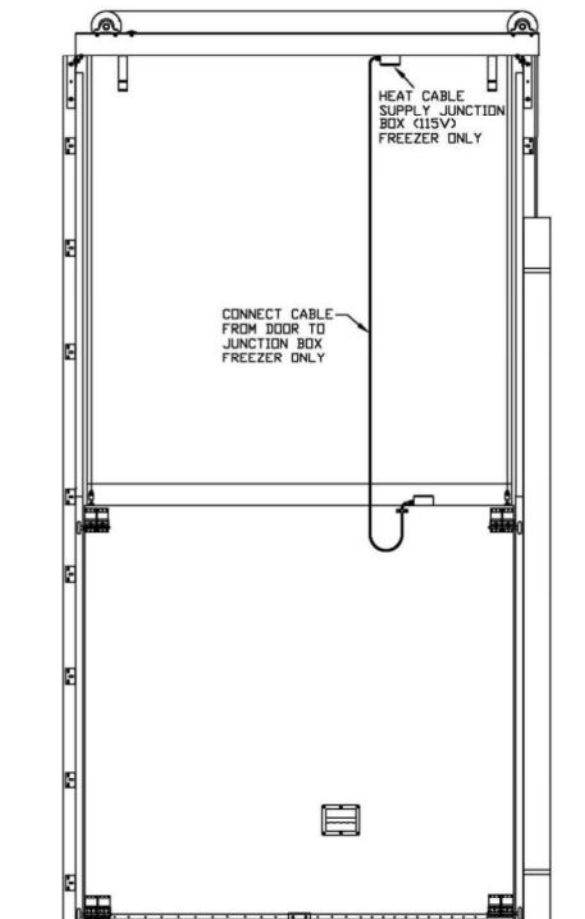

SINGLE VERTICAL SLIDE

If the door has optional heated seals, run cables from seals through clips fastened to header and casings, connect cables as shown.

Heating cable should be left on continuously if temperature is 32 degrees F or lower. 115-volt supply is required (by others).

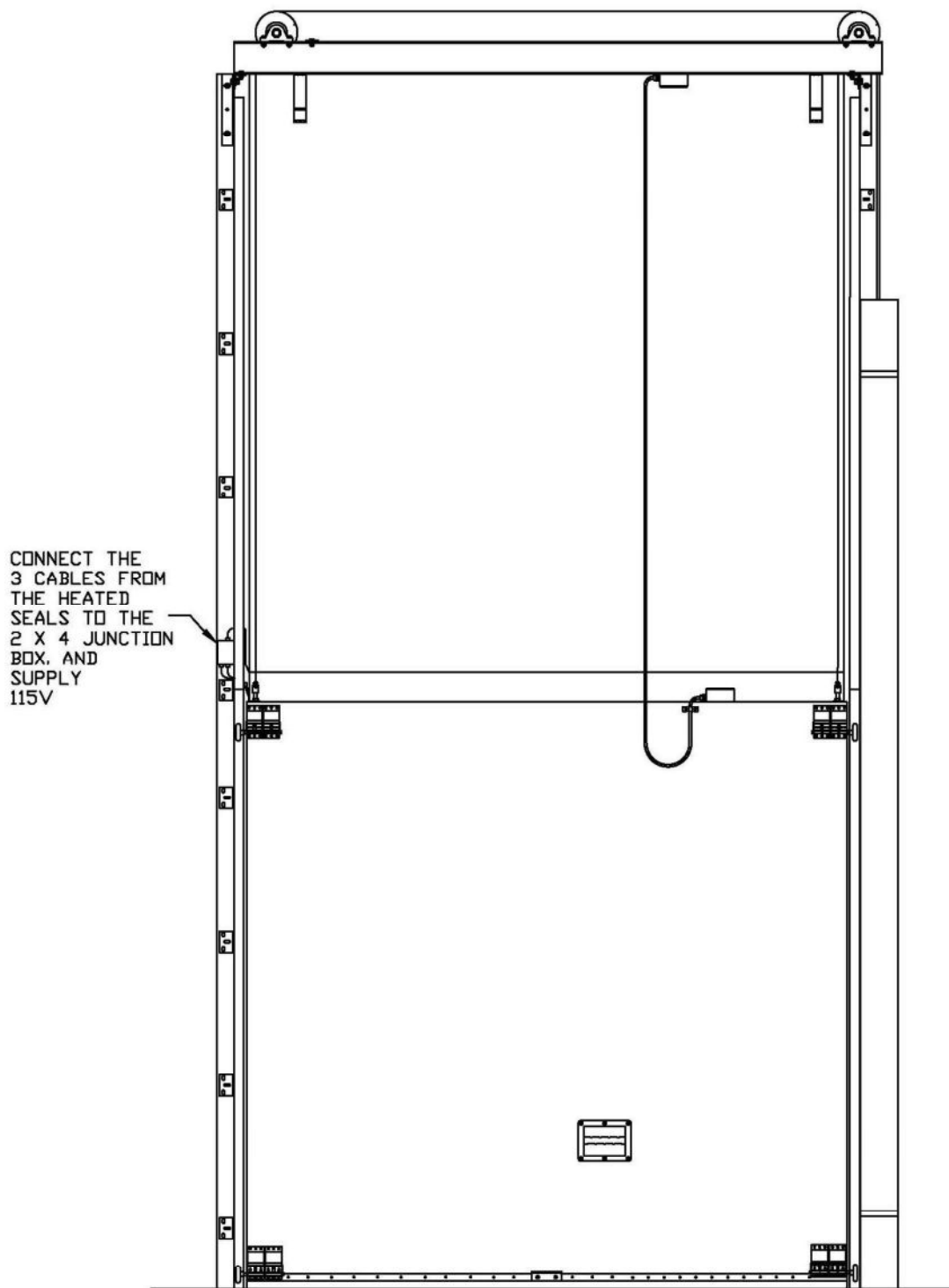

Preventive Maintenance

CHAIN LUBRICATION

The majority of chains used in industry suffer unnecessarily short lives. In most cases, however, the problem is not the fault of the chains but rather the method in which they are lubricated.

The current chain lubrication practice consists of applying a heavy oil or grease to the outside of the chain. While this does a nice job of lubricating the sprockets and the outside of the chain, it does little to protect the most vulnerable area of the chain: the contacting surfaces inside the pin and bushing/ plate/ roller/ hook.

The majority of chains fail from the inside. They stretch or kink up due to wear and corrosion wear inside the pin and bushing area. To lubricate them properly, the lubricant needs to be engineered to penetrate and clean the inside of the chain, clean the inside of the chain (to remove contaminants and displace any trapped water that it encounters) and leave behind a heavy film of oil, grease or solid lubricant.

Roller chain consists of a series of connecting traveling metallic bearings, which must be properly lubricated to obtain the maximum service life of the chain. Although many slow-speed drives operate successfully with little or no lubrication beyond the initial factory lubrication, proper lubrication will greatly extend the useful life of every drive chain.

The drive chain requires lubrication for six purposes.

1. To resist wear of the pin-bushing joint.
2. To cushion impact loads.
3. To dissipate any heat generated.
4. To flush away foreign materials.
5. To lubricate chain-sprocket contact surfaces.
6. To retard rust or corrosion

SINGLE VERTICAL SLIDE

DRIVE SYSTEM & TRACK INSPECTION

The drive system is nominally maintenance free, although periodic inspection for loose fasteners, and general operation is still required. Pay careful attention to setscrews and keyways as this is the area that sees the most stress.

GASKET SEALS

A bulb type gasket surrounds the perimeter of the door or opening casing. The purpose of this gasket is to provide a thermal barrier between the cold air on the inside and the warmer air on the outside of the cooler or freezer. This is achieved by trapping the air into a pocket between the door and casing. This trapped air creates a thermal break, which prevents the colder air from escaping out into the warmer air.

The bulb gaskets should be soft and pliable, when inspecting these gaskets you should check if the gaskets are filled with frost, this would make the gasket hard and unable to seal around the door perimeter. Also check for damage such as rips or tears which would allow the trapped air to escape. Any damaged gaskets should be repaired or replaced, as a leaking gasket will result in frost building up at the point where the cold air is allowed to escape.

HEATER EQUIPMENT (Freezer application only):

Heaters are located throughout the door equipment when the application involves temperature below the freezing point. There is a heater located inside the doors sealing surface, which is the area around the perimeter where the bulb seals contact the door. Also a heater is installed in the pull-cord station, which is to be located inside the freezer, to prevent the same condensation from forming.

If the door operating system is located in a freezer, heaters are installed in the control panel as well as the drive motor. The heater inside the control panel prevents the air inside the control panel from condensing and settling on the electronic equipment. The heater mounted underneath the drive motor is there to keep the internal lubrication temperature of the gear unit high enough to allow it to remain fluid.

Preventative Maintenance	Daily Door Usage		
	Light Usage 1 to 20 Cycles	Medium Usage 20 to 100 Cycles	Heavy Usage 100+ Cycles
Chain Lubrication	Every 24 Months	Every 12 Months	Every 6 Months
Chain Tension	Every 6 Months	Every 12 Months	Every Month
Bulb Seal Inspection	Annually	Annually	Annually



 CROWNTONKA®  ICS™  LOTEMP DOORS™  PREPRITE®  THERMALRITE®

Proud to be family-owned.